

# NOTICE OF PROPOSED DEVELOPMENT

Notice is hereby given that an application has been made for planning approval for the following development:

**SITE: 8 Spoonbill Loop, Sorell (CT187/106/30)**

**PROPOSED DEVELOPMENT:**

**DWELLING**

The relevant plans and documents can be inspected at the Council Offices at 47 Cole Street, Sorell during normal office hours, or the plans may be viewed on Council's website at [www.sorell.tas.gov.au](http://www.sorell.tas.gov.au) until **Monday 5<sup>th</sup> August 2024**.

Any person may make representation in relation to the proposal by letter or electronic mail ([sorell.council@sorell.tas.gov.au](mailto:sorell.council@sorell.tas.gov.au)) addressed to the General Manager. Representations must be received no later than **Monday 5<sup>th</sup> August 2024**.

**APPLICANT: Wilson Homes Pty Ltd**

**APPLICATION NO: DA 2024 / 72 - 1**

**DATE: 18 July 2024**



8 Spoonbill Loop, Sorell (CT187106/30) - Representation Close Monday 5th August 2024

18-Jul-2024



Disclaimer: This map is a representation of the information currently held by Sorell Council. While every effort has been made to ensure the accuracy of the product, Council accepts no responsibility for any errors or omissions. Any feedback on omissions or errors would be appreciated.

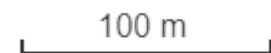

Part B: Please note that Part B of this form is publicly exhibited.

Full description of Proposal:	Use: <i>New Building</i>
	Development: <i>Dwelling</i>
	<i>Large or complex proposals should be described in a letter or planning report.</i>

Design and construction cost of proposal:	\$ ...420,000..... .....
---	--------------------------------

Is all, or some the work already constructed:	No: <input checked="" type="checkbox"/> Yes: <input type="checkbox"/>
---	---

Location of proposed works:	Street address Lot 30 Spoonbill Loop...Suburb: Sorell ... Postcode: 7172.... Certificate of Title(s) Volume: ..... Folio: .....
-----------------------------	--



**Sorell Council**  
Development Application: Development Application -Lot 30 Spoonbill Loop, Sorell - P1.pdf  
Plans Reference:P1  
Date Received:12/04/2024

Current Use of Site	Vacant Land...
---------------------	----------------

Current Owner/s:	Name(s) Jac Group.....
------------------	------------------------

Is the Property on the Tasmanian Heritage Register?	No: <input type="checkbox"/> Yes: <input type="checkbox"/>	<i>If yes, please provide written advice from Heritage Tasmania</i>
Is the proposal to be carried out in more than one stage?	No: <input type="checkbox"/> Yes: <input type="checkbox"/>	<i>If yes, please clearly describe in plans</i>
Have any potentially contaminating uses been undertaken on the site?	No: <input type="checkbox"/> Yes: <input type="checkbox"/>	<i>If yes, please complete the Additional Information for Non-Residential Use</i>
Is any vegetation proposed to be removed?	No: <input type="checkbox"/> Yes: <input type="checkbox"/>	<i>If yes, please ensure plans clearly show area to be impacted</i>
Does the proposal involve land administered or owned by either the Crown or Council?	No: <input type="checkbox"/> Yes: <input type="checkbox"/>	<i>If yes, please complete the Council or Crown land section on page 3</i>

If a new or upgraded vehicular crossing is required from Council to the front boundary please complete the Vehicular Crossing (and Associated Works) application form  
<https://www.sorell.tas.gov.au/services/engineering/>

**Declarations and acknowledgements**

- I/we confirm that the application does not contradict any easement, covenant or restriction specified in the Certificate of Title, Schedule of Easements or Part 5 Agreement for the land.
- I/we consent to Council employees or consultants entering the site and have arranged permission and/or access for Council’s representatives to enter the land at any time during normal business hours.
- I/we authorise the provision of a copy of any documents relating to this application to any person for the purposes of assessment or public consultation and have permission of the copyright owner for such copies.
- I/we declare that, in accordance with s52(1) of the *Land Use Planning and Approvals Act 1993*, that I have notified the owner(s) of the intention to make this application.
- I/we declare that the information in this application is true and correct.

*Details of how the Council manages personal information and how you can request access or corrections to it is outlined in Council’s Privacy Policy available on the Council website.*

- I/we acknowledge that the documentation submitted in support of my application will become a public record held by Council and may be reproduced by Council in both electronic and hard copy format in order to facilitate the assessment process, for display purposes during public exhibition, and to fulfil its statutory obligations. I further acknowledge that following determination of my application, Council will store documentation relating to my application in electronic format only.
- Where the General Manager’s consent is also required under s.14 of the *Urban Drainage Act 2013*, by making this application I/we also apply for that consent.

Applicant Signature:	Signature: ..... Date: .....
----------------------	------------------------------

**Crown or General Manager Land Owner Consent**

If the land that is the subject of this application is owned or administered by either the Crown or Sorell Council, the consent of the relevant Minister or the Council General Manager whichever is applicable, must be included here. This consent should be completed and signed by either the General Manager, the Minister, or a delegate (as specified in s52 (1D-1G) of the *Land Use Planning and Approvals Act 1993*).

- Please note:
- If General Manager consent is required, please first complete the General Manager consent application form available on our website [www.sorell.tas.gov.au](http://www.sorell.tas.gov.au)
  - If the application involves Crown land you will also need a letter of consent.
  - Any consent is for the purposes of making this application only and is not consent to undertaken work or take any other action with respect to the proposed use or development.

I \_\_\_\_\_ being responsible for the administration of land at \_\_\_\_\_ declare that I have given permission for the making of this application for \_\_\_\_\_



**Sorell Council**

Development Application: Development Application -Lot 30 Spoonbill Loop, Sorell - P1.pdf

Plans Reference:P1

Date Received:12/04/2024

Signature of General Manager, Minister or Delegate:	 Signature: _____
---	--



**Sorell Council**

Development Application: Development  
Application -Lot 30 Spoonbill Loop, Sorell - P1.pdf

Plans Reference:P1  
Date Received:12/04/2024

# **AS2870:2011 SITE ASSESSMENT**

**Lot 30 Pittwater Shores Estate**

**Sorell**

**February 2024**

*Wilson Homes Reference: 713965/0200*



GEO-ENVIRONMENTAL  
SOLUTIONS



Disclaimer: The author does not warrant the information contained in this document is free from errors or omissions. The author shall not in any way be liable for any loss, damage or injury suffered by the User consequent upon, or incidental to, the existence of errors in the information.

## Investigation Details

<b>Client:</b>	Wilson Homes
<b>Site Address:</b>	Lot 30 Pittwater Shores Estate, Sorell
<b>Date of Inspection:</b>	16/02/2024
<b>Proposed Works:</b>	New house
<b>Investigation Method:</b>	Geoprobe 540UD - Direct Push
<b>Inspected by:</b>	M. Campbell

## Site Details

<b>Certificate of Title (CT):</b>	TBC
<b>Title Area:</b>	Approx. 470 m <sup>2</sup>
<b>Applicable Planning Overlays:</b>	Priority Vegetation , Airport obstacle limitation area, Waterway and Coastal Protection Areas
<b>Slope &amp; Aspect:</b>	Flat with no dominant aspect facing slope
<b>Vegetation:</b>	Grass & Weeds Fill

## Background Information

<b>Geology Map:</b>	MRT
<b>Geological Unit:</b>	Tertiary Basalt
<b>Climate:</b>	Annual rainfall 550mm
<b>Water Connection:</b>	Mains
<b>Sewer Connection:</b>	Serviced-Mains
<b>Testing and Classification:</b>	AS2870:2011, AS1726:2017 & AS4055:2021

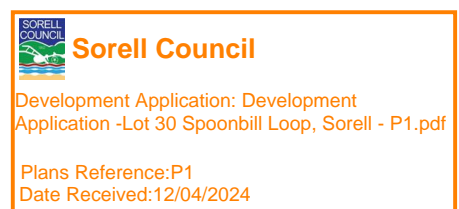

## Investigation

A number of bore holes were completed to identify the distribution and variation of the soil materials at the site, bore hole locations are indicated on the site plan. See soil profile conditions presented below. Tests were conducted across the site to obtain bearing capacities of the material at the time of this investigation.

### **Soil Profile Summary**

BH 1 Depth (m)	BH 2 Depth (m)	USCS	Description
0.00-0.10	0.00-0.20	CI	FILL: <b>Silty CLAY</b> : medium plasticity, dark grey, brown, slightly moist, stiff
0.10-2.10	0.20-2.10	CH	<b>Silty CLAY</b> : high plasticity, dark grey, yellow, brown, slightly moist, firm to stiff,
2.10-2.30	2.10-2.20	GC	<b>Clayey GRAVEL</b> : medium plasticity, yellow, dry very dense, refusal.

## Site Notes

Soils on the site are developing from Tertiary basalt, the clay fraction is likely to show significant ground surface movement with moisture fluctuations.

## Site Classification

The site has been assessed and classified in accordance with AS2870:2011 “Residential Slabs and Footings”.

The site has been classified as:

**Class P**

Y<sup>s</sup> range: **75-85mm**

Notes: due to low bearing capacity of the underlying soil





**Wind Loading Classification**

According to “AS4055:2021 - Wind Loads for Housing” the house site is classified below:

<b>Wind Classification:</b>	<b>N3</b>
Region:	A
Terrain Category:	1.0
Shielding Classification:	NS
Topographic Classification:	T1
Wind Classification:	N3
Design Wind Gust Speed – m/s ( $V_{h,u}$ ):	50

**Construction Notes & Recommendations**

The site has been classified as **Class P** - see 'Site Classification' above.

All foundations must penetrate through any fill material & topsoil and into the residual soil/gravel below with bearing capacities >100kPa.

All earthworks on site must comply with AS3798:2012, and I further recommend that consideration be given to drainage and sediment control on site during and after construction. Care should also be taken to ensure there is adequate drainage in the construction area to avoid the potential for weak bearing and foundation settlement associated with excessive soil moisture.

I also recommend that during construction that I and/or the design engineer be notified of any major variation to the foundation conditions as predicted in this report.



Dr John Paul Cumming B.Agr.Sc (hons) PhD CPSS GAICD

Director



**Sorell Council**

Development Application: Development Application -Lot 30 Spoonbill Loop, Sorell - P1.pdf

Plans Reference:P1  
Date Received:12/04/2024

## Explanatory Notes

### 1 Scope of Works

The methods of description and classification of soils used in this report are based largely on Australian Standard 1726 – Geotechnical Site Investigations (AS1726:2017), with reference to Australian Standard 1289 – Methods for testing soils for engineering purposes (AS1289), for eventual Site Classification according to Australian Standard 2870 (AS2870:2011) – Residential Slabs and Footings and Australian Standard 1547 (AS1547:2012) On-site domestic wastewater management.

#### 1.1 Site Classification AS2870:2011

Site classification with reference to the above Australian Standards are based on site reactivity.

Class	Foundation Conditions	Characteristic Surface Movement
A	Most sand and rock sites with little or no ground movement from moisture changes.	0mm
S	Slightly reactive clay sites, which may experience only slight ground movement from moisture changes.	0 – 20mm
M	Moderately reactive clay or silt sites, which may experience moderate ground movement from moisture changes.	20 – 40mm
H-1	Highly reactive clay sites, which may experience high ground movement from moisture changes.	40 – 60mm
H-2	Highly reactive clay sites, which may experience very high ground movement from moisture changes.	60 – 75mm
E	Extremely reactive sites, which may experience extreme ground movement from moisture changes.	>75mm

*Note: Soils where foundation performance may be significantly affected by factors other than reactive soil movement are classified as **Class P**.*

A site is classified as **Class P** when:

- The bearing capacity of the soil profile in the foundation zone is generally less than 100kpa
- If excessive foundation settlement may occur due to loading on the foundation.
- The site contains uncontrolled fill greater than 0.8m in depth for sandy sites and 0.4m in depth for other soil materials.
- The site is subject to mine subsidence, landslip, collapse activity or coastal erosion.
- The site is underlain by highly dispersive soils with significant potential for erosion
- If the site is subject to abnormal moisture conditions which can affect foundation performance



## 1.2 Soil Characterisation

This information explains the terms of phrase used within the soil description area of the report.

It includes terminology for cohesive and non-cohesive soils and includes information on how the Unified Soil Classification Scheme (USCS) codes are determined.

<b>NON COHESIVE – SAND &amp; GRAVEL</b>		
<b>Consistency Description</b>	<b>Field Test</b>	<b>Dynamic Cone Penetrometer blows/100 mm</b>
Very loose (VL)	Easily penetrated with 13 mm reinforcing rod pushed by hand.	0 - 1
Loose (L)	Easily penetrated with 13 mm reinforcing rod pushed by hand. Can be excavated with a spade; 50 mm wooden peg can be easily driven.	1 - 3
Medium dense (MD)	Penetrated 300 mm with 13 mm reinforcing rod driven with 2 kg hammer, - hard shovelling.	3 - 8
Dense (D)	Penetrated 300 mm with 13 mm reinforcing rod driven with 2 kg hammer, requires pick for excavation: 50 mm wooden peg hard to drive.	8 - 15
Very dense (VD)	Penetrated only 25 - 50 mm with 13 mm reinforcing rod driven with 2 kg hammer.	>15

<b>COHESIVE - SILT &amp; CLAY</b>		
<b>Consistency Description</b>	<b>Field Test</b>	<b>Indicative undrained shear strength kPa</b>
Very soft	Easily penetrated >40 mm by thumb. Exudes between thumb and fingers when squeezed in hand.	<12
Soft	Easily penetrated 10 mm by thumb. Moulded by light finger pressure	>12 and <25
Firm	Impression by thumb with moderate effort. Moulded by strong finger pressure	>25 and <50
Stiff	Slight impression by thumb cannot be moulded with finger.	>50 and <100
Very Stiff	Very tough. Readily indented by thumbnail.	>100 and <200
Hard	Brittle. Indented with difficulty by thumbnail.	>200



**Sorell Council**

Development Application: Development Application -Lot 30 Spoonbill Loop, Sorell - P1.pdf

Plans Reference:P1  
Date Received:12/04/2024

### 1.3 USCS Material Descriptions

Soils for engineering purposes are the unconsolidated materials above bedrock, they can be residual, alluvial, colluvial or aeolian in origin.

Major Divisions		Particle size mm	USCS Group Symbol	Typical Names	Laboratory Classification				NOTES	
COARSE GRAINED SOILS (more than half of material less than 63 mm is larger than 0.075 mm)	BOULDERS	200			% < 0.075 mm (2)	Plasticity of fine fraction	$C_u = \frac{D_{60}}{D_{10}}$	$C_c = \frac{(D_{30})^2}{(D_{10})(D_{60})}$	(1) Identify fines by the method given for fine-grained soils.  (2) Borderline classifications occur when the percentage of fines (fraction smaller than 0.075 mm size) is greater than 5% and less than 12%. Borderline classifications require the use of SP-SM, GW-GC.	
	COBBLES	63								
	GRAVELS (more than half of coarse fraction is larger than 2.36 mm)	coarse	20	GW	Well graded gravels and gravel-sand mixtures, little or no fines	0-5	—	>4		Between 1 and 3
		medium	6	GP	Poorly graded gravels and gravel-sand mixtures, little or no fines, uniform gravels	0-5	—	Fails to comply with above		
		fine	2.36	GM	Silty gravels, gravel-sand-silt mixtures (1)	12-50	Below 'A' line or PI<4	—		—
				GC	Clayey gravels, gravel-sand-clay mixtures (1)	12-50	Above 'A' line and PI>7	—		—
	SANDS (more than half of coarse fraction is smaller than 2.36 mm)	coarse	0.6	SW	Well graded sands and gravelly sands, little or no fines	0-5	—	>6		Between 1 and 3
		medium	0.2	SP	Poorly graded sands and gravelly sands, little or no fines	0-5	—	Fails to comply with above		
		fine	0.075	SM	Silty sands, sand silt mixtures (1)	12-50	Below 'A' line or PI<4	—		—
				SC	Clayey sands, sand-clay mixtures (1)	12-50	Above 'A' line and PI>7	—		—
FINE GRAINED SOILS (more than half of material less than 63 mm is smaller than 0.075 mm)	SILTS & CLAYS (Liquid Limit ≤50%)	ML	Inorganic silts, very fine sands, rock flour, silty or clayey fine sands or clayey silts with slight plasticity	Use the gradation curve of material passing 63 mm for classification of fractions according to the criteria given in 'Major Divisions'	<b>Plasticity Chart</b> For classification of fine grained soils and fine fraction of coarse grained soils.					
		CL CI	Inorganic clays of low to medium plasticity, gravelly clays, sandy clays, silty clays, lean clays							
		OL	Organic silts and clays of low plasticity							
	SILTS & CLAYS (Liquid Limit >50%)	MH	Inorganic silts, mic-aceous or diato-maceous fine sands or silts, elastic silts							
		CH	Inorganic clays of high plasticity, fat clays							
		OH	Organic silts and clays of high plasticity							
	HIGHLY ORGANIC SOILS	PT	Peat and other highly organic soils							

**Sorell Council**  
 Development Application: Development Application -Lot 30 Spoonbill Loop, Sorell - P1.pdf  
 Plans Reference:P1  
 Date Received:12/04/2024

Grain size analysis is performed by two processes depending on particle size. Sand silt and clay particles are assessed using a standardised hydrometer test, and coarse sand and larger is assessed through sieving by USCS certified sieves. For more detail see the following section.

Soil Classification	Particle Size
Clay	Less than 0.002mm
Silt	0.002 – 0.06mm
Fine/Medium Sand	0.06 – 2.0mm
Coarse Sand	2.0mm – 4.75mm
Gravel	4.75mm – 60.00mm

#### 1.4 Bearing Capacities and DCP testing.

DCP and PSP weighted penetrometer tests – Dynamic Cone Penetrometer (DCP) and Perth Sand Penetrometer (PSP) tests are carried out by driving a rod into the ground with a falling weight hammer and measuring the blows for successive 100mm increments of penetration. Normally, there is a depth limitation of 1.2m but this may be extended in certain conditions by the use of extension rods. The methods for the two tests are quite similar.

- Dynamic Cone Penetrometer – a 16mm rod with a 20mm diameter cone end is driven with a 9kg hammer dropping 510mm (AS 1289, Test 6.3.2).
- Perth Sand Penetrometer – a 16mm diameter flat-ended rod is driven with a 9kg hammer, dropping 600mm (AS 1289 Test 6.3.3). This test was developed for testing the density of sands and is mainly used in granular soils and filling.

Site Anomalies – During construction GES will need to be notified of any major variation to the foundation conditions as predicted in this report.



**Sorell Council**

Development Application: Development Application -Lot 30 Spoonbill Loop, Sorell - P1.pdf

Plans Reference:P1  
Date Received:12/04/2024

**1.5 Batter Angles for Embankments (Guide Only)**

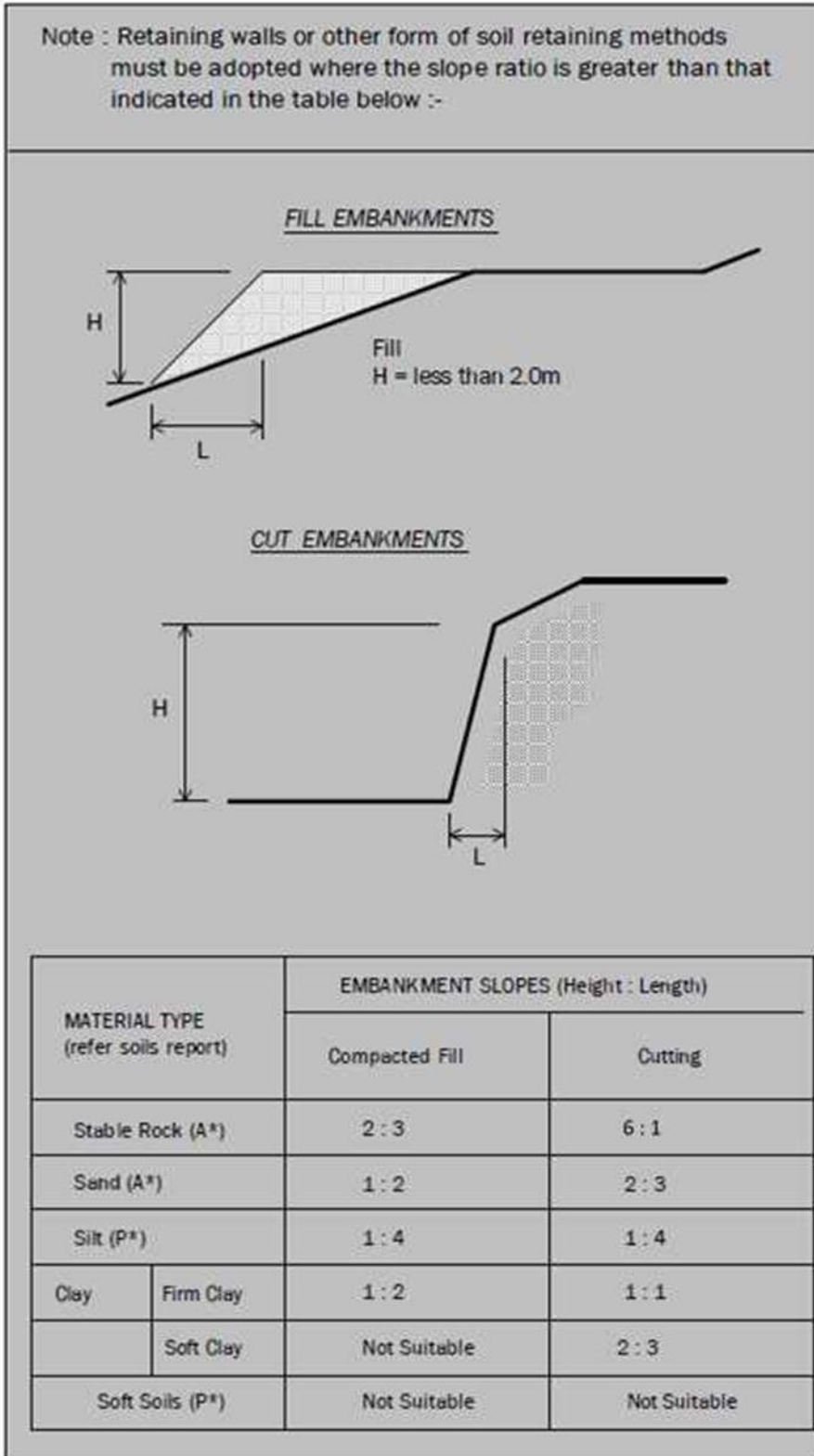

## Glossary of Terms

**Bearing Capacity** – Maximum bearing pressure that can be sustained by the foundation from the proposed footing system under service loads which should avoid failure or excessive settlement.

**Clay** – (Mineral particles less than 0.002mm in diameter). Fine grained cohesive soil with plastic properties when wet. Also includes sandy clays, silty clays, and gravelly clays.

**Dynamic Cone Penetrometer (DCP)** – Field equipment used to determine underlying soil strength and therefore bearing capacity (kPa) by measuring the penetration of the device into the soil after each hammer blow.

**Dispersive soil** – A soil that has the ability to pass rapidly into suspension in water.

**Footing** – Construction which transfers the load from the building to the foundation.

**Foundation** – Ground which supports the building

**Landslip** – Foundation condition on a sloping site where downhill foundation movement or failure is a design consideration.

**Qualified Engineer** – A professional engineer with academic qualifications in geotechnical or structural engineering who also has extensive experience in the design of the footing systems for houses or similar structures.

**Reactive Site** – Site consisting of clay soil which swells on wetting and shrinks on drying by an amount that can damage buildings on light strip footings or unstiffened slabs. Includes sites classified as S, M, H-1, H-2 & E in accordance with AS2870-2011.

**Sand** – (Mineral particles greater than 0.02mm in diameter). Granular non-cohesive, non-plastic soil that may contain fines including silt or clay up to 15%.

**Services** – Means all underground services to the site including but not limited to power, telephone, sewerage, water & storm water.

**Silt** – (Mineral particles 0.002 – 0.02mm in diameter). Fine grained non-cohesive soil, non-plastic when wet. Often confers a silky smoothness of field texture, regularly includes clay and sand to form clayey silts, sandy silts and gravelly silts.

**Site** – The site title, as denoted by address, lot number, or Certificate of Title (CT) number, or Property Identification Number (PID).

**Surface Movement (Ys)** – Design movement (mm) at the surface of a reactive site caused by moisture changes.

## Disclaimer

This Report has been prepared in accordance with the scope of services between Geo-Environmental Solutions Pty. Ltd. (GES) and the Client. To the best of GES's knowledge, the information presented herein represents the client's requirements at the time of printing of the Report. However, the passage of time, manifestation of latent conditions or impacts of future events may result in findings differing from that discussed in this Report. In preparing this Report, GES has relied upon data, surveys, analyses, designs, plans and other information provided by the Client and other individuals and organisations referenced herein. Except as otherwise stated in this Report, GES has not verified the accuracy or completeness of such data, surveys, analyses, designs, plans and other information.

The scope of this study does not allow for the review of every possible geotechnical parameter or the soil conditions over the whole area of the site. Soil and rock samples collected from the investigation area are assumed to be representative of the areas from where they were collected and not indicative of the entire site. The conclusions discussed within this report are based on observations and/or testing at these investigation points.

This report does not purport to provide legal advice. Readers of the report should engage professional legal practitioners for this purpose as required.

No responsibility is accepted for use of any part of this report in any other context or for any other purpose by third a party.



**Site Plan**

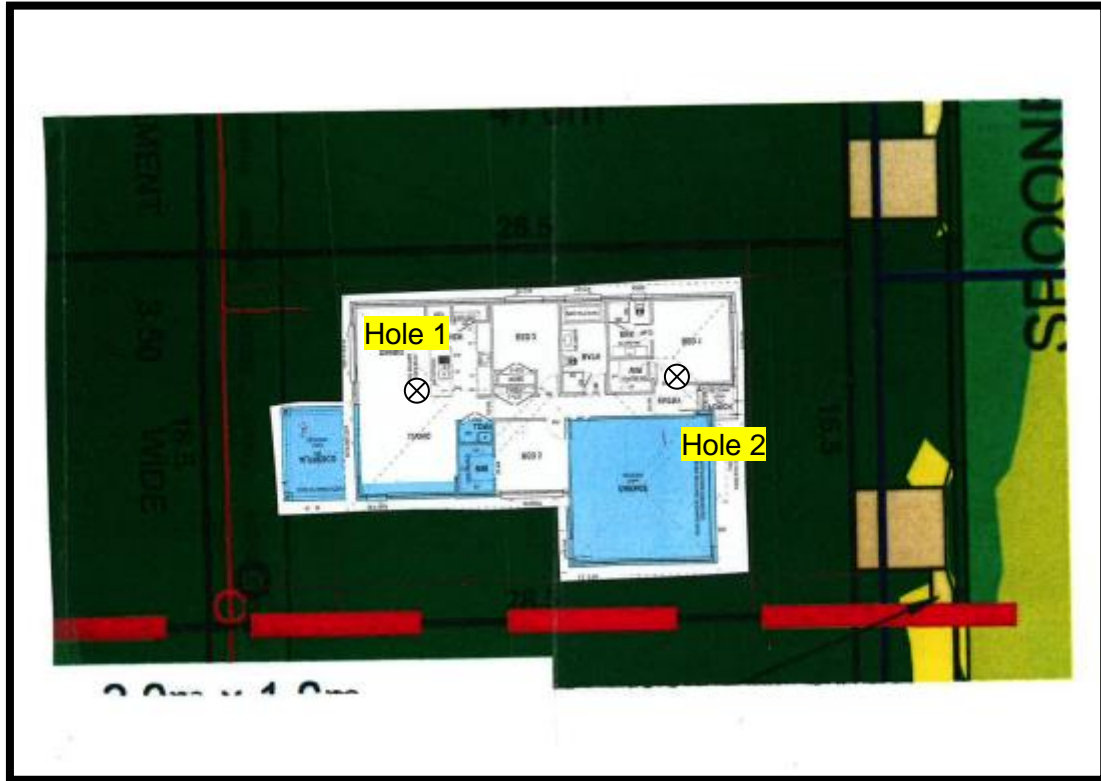

 **Sorell Council**  
Development Application: Development  
Application -Lot 30 Spoonbill Loop, Sorell - P1.pdf  
Plans Reference:P1  
Date Received:12/04/2024

## APPENDIX 1 - DCP Results Table

**Dynamic Cone Penetration (DCP) Conversion to Californian Bearing Ratio**  
 (ref: Australian Standard AS 1289.6.3.2 - 1997)

DCP Location                      BH1

Depth (mm)	DCP (Blows/100mm)	DCP (mm/Blow)	DCP Resistance (mPa)	Allowable Bearing Capacity (kPa)	CBR (Rounded Up)
0-100	4	25.0	1.3	139	8
100-200	5	20.0	1.6	174	10
200-300	3	33.3	0.9	104	6
300-400	3	33.3	0.9	104	6
400-500	3	33.3	0.9	104	6
500-600	2	50.0	0.6	69	4
600-700	2	50.0	0.6	69	4
700-800	1	100.0	0.3	35	2
800-900	2	50.0	0.6	69	4
900-1000	2	50.0	0.6	69	4
1000-1100	5	20.0	1.6	174	10
1100-1200	6	16.7	1.9	208	13
1200-1300	8	12.5	2.5	278	17
1300-1400	7	14.3	2.2	243	15
1400-1500	6	16.7	1.9	208	13
1500-1600	6	16.7	1.9	208	13
1600-1700	9	11.1	2.8	313	20
1700-1800	12	8.3	3.8	417	27
1800-1900	14	7.1	4.4	486	32
1900-2000	19	5.3	5.9	660	45



**Sorell Council**

Development Application: Development  
 Application -Lot 30 Spoonbill Loop, Sorell - P1.pdf

Plans Reference:P1  
 Date Received:12/04/2024

# CERTIFICATE OF QUALIFIED PERSON – ASSESSABLE ITEM

Section 321

Form **55**

To:  Owner /Agent  
 Address  
  Suburb/postcode

## Qualified person details:

Qualified person:   
Address:  Phone No:   
  Fax No:   
Licence No:  Email address:

Qualifications and Insurance details:  (description from Column 3 of the Director's Determination - Certificates by Qualified Persons for Assessable Items)

Speciality area of expertise:  (description from Column 4 of the Director's Determination - Certificates by Qualified Persons for Assessable Items)

## Details of work:

Address:  Lot No:   
  Certificate of title No:

The assessable item related to this certificate:  (description of the assessable item being certified)  
Assessable item includes –  
- a material;  
- a design  
- a form of construction  
- a document  
- testing of a component, building system or plumbing system  
- an inspection, or assessment, performed

## Certificate details:

Certificate type:  (description from Column 1 of Schedule 1 of the Director's Determination - Certificates by Qualified Persons for Assessable Items n)

This certificate is in relation to the above assessable item, at any stage, as part of - (tick one)

building work, plumbing work or plumbing installation or demolition work   
or

a building, temporary structure or plumbing installation:

 **Sorell Council**  
Development Application: Development Application -Lot 30 Spoonbill Loop, Sorell - P1.pdf  
Plans Reference:P1  
Date Received:12/04/2024

In issuing this certificate the following matters are relevant –

Documents:	The attached soil report for the address detailed above in 'details of work'
Relevant calculations:	Reference the above report.
References:	AS2870:2011 residential slabs and footings AS1726:2017 Geotechnical site investigations CSIRO Building technology file – 18.

*Substance of Certificate: (what it is that is being certified)*

Site Classification consistent with AS2870-2011.

*Scope and/or Limitations*

The classification applies to the site as inspected and does not account for future alteration to foundation conditions as a result of earth works, drainage condition changes or variations in site maintenance.

**I, John-Paul Cumming certify the matters described in this certificate.**

Qualified person:

*Signed:*

*Certificate No:*

*Date:*

J10016

08/03/2024



A handwritten signature in black ink, appearing to read 'John Paul Cumming', written over a light grey background.

 <b>Sorell Council</b>
Development Application: Development Application -Lot 30 Spoonbill Loop, Sorell - P1.pdf
Plans Reference:P1 Date Received:12/04/2024

## 8 (Lot 30) Spoonbill Loop, Sorell: Natural Values Statement



28 Suncrest Avenue  
Lenah Valley, TAS 7008  
mark@ecotas.com.au  
www.ecotas.com.au  
0407 008 685  
**ABN 83 464 107 291**

### Wilson Homes Tasmania Pty Ltd

ATTENTION: Sonya Gadd (Project Coordinator)  
250 Murray Street  
Hobart TAS 7000



12 July 2024

Dear Sonya

**RE: 8 (Lot 30) Spoonbill Loop, Sorell (PID 9066476; C.T. 187106/30)  
Proposed Development/Use – Single Residential Dwelling**

### **Preamble**

I refer to engagement to assess the natural values of 8 (Lot 30) Spoonbill Loop, Sorell, specifically to address matters likely to be requested by Sorell Council as part of a planning application in relation to C7.6.1 P1.1 & P1.2 of the Natural Assets Code of the *Tasmanian Planning Scheme – Sorell Local Provisions Schedule* (understood to be lodged and now recognised as 5.2024.72.1).

It is noted the Priority Vegetation Area overlay is also present across the title, but because the title is zoned as General Residential the Natural Assets Code has no application in relation to this overlay.

### **Site details**

Address: 8 (Lot 30) Spoonbill Loop, Sorell

PID: 9066476; C.T.: 187106/30; LPI: JWE56

Zone: General Residential

Overlays (relevant to the present assessment): Waterway and Coastal Protection Area (Natural Assets Code) – see notes below

The overlay is 100 m wide, but set well back from the high tide mark. It is assumed that the overlay is related directly to the presence of the Ramsar wetland referred to as Pitt Water-Orielton Lagoon.

Area: measured area = 470 m<sup>2</sup> [source: LISTmap]

Topography: flat terrain.

Current land use: previous disused pasture now developed as completely developed as a residential subdivision, with all roads and services already approved and constructed (Plates 1-4)

Drainage features: none present



## 8 (Lot 30) Spoonbill Loop, Sorell: Natural Values Statement



**Plate 1.** (LHS) Current land use of Lot 30 Spoonbill Loop showing wholly cleared land with no native vegetation present



**Plate 2.** (RHS) Existing formed access and services of Lot 30 Spoonbill Loop



**Plate 3.** (LHS) View along Spoonbill Loop showing fully developed subdivision with all services provided



**Plate 4.** (RHS) Example of existing service along Spoonbill Loop

### **Proposal**

The proposal is for a single residential dwelling.

### **Assessment**

#### Preliminary database checks

LISTmap was examined to determine existing vegetation mapping and known sites for threatened flora and fauna. Database reports were produced under DNRET's *Natural Values Atlas*, the Forest Practices Authority's *Biodiversity Values Database* and the Commonwealth *Protected Matters Report* to support the assessment process.



Site assessment

I attended the site on 11 Jul. 2024.

**Findings**

Vegetation types

All versions of TASVEG (3.0, 4.0 & Live) indicate the subject title is mapped as urban areas (TASVEG code: FUR), correctly reflecting the current status of the land i.e. there is no need for a revised vegetation map as the site is now wholly developed for sale and occupation of small lots.

Threatened flora

Database information indicates that the subject title does not support known populations of flora listed as threatened on either the Tasmanian *Threatened Species Protection Act 1995* or the Commonwealth *Environment Protection and Biodiversity Protection Act 1999*. Site assessment did not detect any such species.

Threatened fauna

Database information indicates that the subject title does not support known populations of fauna listed as threatened on either the Tasmanian *Threatened Species Protection Act 1995* or the Commonwealth *Environment Protection and Biodiversity Protection Act 1999*. Site assessment did not detect any such species, nor significant potential habitat of such species.

**Consideration of planning scheme requirements**

The Purpose of the Natural Assets Code is stated as:

C7.0 Natural Assets Code

C7.1 Code Purpose

The purpose of the Natural Assets Code is:

- C7.1.1 To minimise impacts on water quality, natural assets including native riparian vegetation, river condition and the natural ecological function of watercourses, wetlands and lakes.
- C7.1.2 To minimise impacts on coastal and foreshore assets, native littoral vegetation, natural coastal processes and the natural ecological function of the coast.
- C7.1.3 To protect vulnerable coastal areas to enable natural processes to continue to occur, including the landward transgression of sand dunes, wetlands, saltmarshes and other sensitive coastal habitats due to sea-level rise.
- C7.1.4 To minimise impacts on identified priority vegetation.
- C7.1.5 To manage impacts on threatened fauna species by minimising clearance of significant habitat.

RESPONSE: Of these purpose statements, C7.1.1 & C7.1.2 have the most relevant application as the overlay is directly related to the adjacent Ramsar wetland.



## 8 (Lot 30) Spoonbill Loop, Sorell: Natural Values Statement

The Code has the following application:

- C7.2 Application of this Code
- C7.2.1 This code applies to development on land within the following areas:
  - (a) a waterway and coastal protection area;
- C7.2.2 This code does not apply to use.

RESPONSE: C7.2.1(a) is applicable.

The Development Standards for Buildings and Works (C7.6) and specifically those for Buildings and Works within a Waterway and Coastal Protection Area or Future Coastal Refugia Area (last not relevant) are stated below:

- C7.6 Development Standards for Buildings and Works
- C7.6.1 Buildings and works within a waterway and coastal protection area or a future coastal refugia area

Objective: That buildings and works within a waterway and coastal protection area or future coastal refugia area will not have an unnecessary or unacceptable impact on natural assets.

RESPONSE: While there will be works within the technical overlay it is very difficult to anticipate a scenario in which such works would "have an unnecessary or unacceptable impact on natural assets" given the wholly modified status of the title. The title is one of several small new titles released on previously farmed land, wholly approved by Sorell Council for the primary purpose of residential development, with roads and services all already established. Spoonbill Loop is fully sealed and furnished with sealed concrete footpaths and drains adjacent to the title. It is a reasonable assumption that the approval of the subdivision took due account of the potential direct and/or indirect immediate and/or future impacts on the adjacent Ramsar wetland. That is, I do not find the intent of the objective statement will be compromised by the now proposed development.

The Acceptable Solution A1 of C7.6.1 is stated as:

- A1
- Buildings and works within a waterway and coastal protection area must:
  - (a) be within a building area on a sealed plan approved under this planning scheme;
  - (b) in relation to a Class 4 watercourse, be for a crossing or bridge not more than 5 m in width; or
  - (c) if within the spatial extent of tidal waters, be an extension to an existing boat ramp, car park, jetty, marina, marine farming shore facility or slipway that is not more than 20% of the area of the facility existing at the effective date.

RESPONSE: In my interpretation, these provisions are either not met or are not applicable, noting that A1(a) refers to "this planning scheme" and so I presume any approval of the now older subdivision and obviously any subsequent development under the previous scheme is no longer applicable.

The Performance Criteria P1.1 of C7.6.1 is stated as:

- P1.1
- Buildings and works within a waterway and coastal protection area must avoid or minimise adverse impacts on natural assets, having regard to:

RESPONSE: Under the Code, "natural assets" are taken to mean "biodiversity, environmental flows, natural stream bank and stream bed condition, riparian vegetation, littoral vegetation, water quality, wetlands, river condition and waterway and/or coastal values" i.e. they have broad definition and potential application. That said, in this case the highly modified status of





## 8 (Lot 30) Spoonbill Loop, Sorell: Natural Values Statement

the title is reiterated but noting the overlay refers more relevantly to the adjacent Ramsar wetland.

As a starting point, the opening phrase of P1.1 refers to "...must avoid or minimise adverse impacts on natural assets...". The use of the term "minimise" contemplates a level of acceptable impact, although this is not defined anywhere. On the basis that the lot is very small and clearly intended for residential development (and already approved as such by the planning authority), combined with the absence of "natural assets" per se within and adjacent to the title (existing wholly cleared land), in my opinion, the project achieves the objective to "minimise adverse impacts" as far as practicable.

With respect to the phrase "...having regard to...", this is considered in the manner referred to in *S and S McElwaine and A Hamilton v West Tamar Council and Growth Developments Pty Ltd [2021] TASCAT 4 (17 November 2021)*, where TASCAT stated: "the requirement to 'have regard to' does not elevate P2.1(a) to (f) to mandatory requirements that the proposal must satisfy. The tribunal need only consider those subparagraphs in ascertaining whether the proposal complies with clause E8.6.1 P2.1".

Below the sub-criteria of P1.1 are addressed in turn.

- (a) impacts caused by erosion, siltation, sedimentation and runoff;

RESPONSE: To my interpretation, this provision is either not applicable or met by default because there should be limited impacts caused by erosion, siltation, sedimentation and runoff into adjacent areas (noting P1.1 requires impacts to be "avoided **or** minimised"). Based on my site assessment, I struggle to understand that routine construction works that now require a 6-foot fence to be placed around the construction zone would not appropriately manage this risk. It is further noted that the site is on the far eastern side of this approved subdivision, separated from the reserve by two sealed parts of Spoonbill Loop and three lines of lots ready for development, the western section largely already fenced between the lots and the coastal reserve.

- (b) impacts on riparian or littoral vegetation;

RESPONSE: Not applicable because there is no proposal to impact on littoral vegetation with all works intended to be wholly within the existing cleared title. Riparian vegetation is not present.

- (c) maintaining natural streambank and streambed condition, where it exists;

RESPONSE: Not applicable (site does not support any watercourses).

- (d) impacts on in-stream natural habitat, such as fallen logs, bank overhangs, rocks and trailing vegetation;

RESPONSE: Not applicable (site does not support any watercourses).

- (e) the need to avoid significantly impeding natural flow and drainage;

RESPONSE: Not applicable (site does not support any watercourses).

- (f) the need to maintain fish passage, where known to exist;

RESPONSE: Not applicable (site does not support any watercourses).

- (g) the need to avoid land filling of wetlands;

RESPONSE: Not applicable – there is no intention to impact on the wetland in any manner (specifically, no proposal to "land fill" this feature).

- (h) the need to group new facilities with existing facilities, where reasonably practical;

RESPONSE: To my interpretation, this provision is either not applicable.

- (i) minimising cut and fill;

RESPONSE: To my interpretation, this provision is satisfied as there will be limited cut and fill (flat terrain).



## 8 (Lot 30) Spoonbill Loop, Sorell: Natural Values Statement

- (j) building design that responds to the particular size, shape, contours or slope of the land;

RESPONSE: To my interpretation, this provision is satisfied based on the site plans provided, noting this is an approved subdivision that permitted a ca. 470 m<sup>2</sup> title, with no practical options to position a dwelling.

- (k) minimising impacts on coastal processes, including sand movement and wave action;

RESPONSE: In my opinion, provided works are restricted to the title itself, there should be no impact on coastal processes because the site is well above the high water mark and set well back from this mark separated from the reserve by two sealed parts of Spoonbill Loop and three lines of lots ready for development, the western section largely already fenced between the lots and the coastal reserve.

- (l) minimising the need for future works for the protection of natural assets, infrastructure and property;

RESPONSE: In my opinion, this provision has little practical application to a very small title where works will be wholly contained within the title.

- (m) the environmental best practice guidelines in the *Wetlands and Waterways Works Manual*; and

RESPONSE: Not applicable (there will be no works that will manifestly impact on wetlands or waterways).

- (n) the guidelines in the *Tasmanian Coastal Works Manual*

RESPONSE: In my opinion, this manual will have little direct application to the present scenario provided that works are wholly restricted to the title itself.

Based on the above review of P1.1 of C7.6.1, the proposal will fully satisfy all relevant provisions without the need for specific mitigation conditions.

### **Further consideration of Ramsar wetland**

With specific reference to the Ramsar wetland, which is considered to be a Matter of Environmental Significance under the Commonwealth *Environment Protection and Biodiversity Protection Act 1999*, the *Information Sheet on Ramsar Wetlands (RIS) – 2009-2014 version* (CofA 2014) provides extensive background on the Pitt Water – Orielton Lagoon Ramsar site. Under Section 26 (Factors (past, present or potential) adversely affecting the site's ecological character, including changes in land (including water) use and development projects) and specifically under "(b) – factors in the surrounding area", the following information is provided:

"Increasing numbers of subdivisions on the shores of Orielton Lagoon and Midway Point may contribute to increased run-off and sediments. Subdivisions can result in additional stormwater outlets, potential for dumping and spread of weed species, and general disturbance from noise, pets, and human activity. Some of the stormwater is partially treated. Some treatments allow only for the removal of solid pollutants such as litter, while others also reduce sediment and nutrient loads. Stormwater remains an increasing source of nutrients and a significant threat to the environmental quality of Orielton Lagoon.

During 2013/14 leakage from old or damaged sewage infrastructure caused the temporary closure of Oyster farms in Pitt Water area to limit potential public health risk.

Irrigation practices, stock management and ground water manipulation on adjacent agricultural land impact on saltmarshes, seagrass, hydrology, sediment and water quality. Gully erosion, prevalent around Orielton Lagoon, can contribute sediment straight into the wetland. In addition to sedimentation, runoff from planted croplands, pastures and other agricultural areas with high fertiliser use may also contribute to increased nutrient loads in wetland. Nutrient (nitrogen, nitrate and phosphorus) levels in the Coal River are generally at low levels, however, a few high flow events can carry the majority of annual nutrient load (Gallagher 1998).

New developments such as the construction of the South East Irrigation Scheme will increase the amount and type of agricultural cropping in the catchment.



## 8 (Lot 30) Spoonbill Loop, Sorell: Natural Values Statement

The modification of the runways at Cambridge Airport in 2013 has the potential for increased storm water and industrial runoff to the site.

There are a number of proposed developments near the site (e.g. runway extension for Hobart International Airport; new golf course and large residential development at Seven Mile Beach, industrial complex at Barilla Bay) have the potential for increased storm water, industrial runoff, nutrient load and disturbance to bird values of site.

One of the biggest threats to the Pitt Water estuary is likely to be climate change through rising sea level and altered water balance in the catchment area. Inundation of low-lying areas may occur, with erosion and recession of sandy beaches (causing narrowing of the spit), and landward growth and translation of the marine tidal delta”.

It is assumed that the approval of the subdivision took due account of the potential direct and/or indirect immediate and/or future impacts on the adjacent Ramsar wetland meaning that lot-by-lot consideration should not be warranted. In this case, the status of the land and its context (ex-pasture now fully roaded and serviced and separated from the reserve by two sealed parts of Spoonbill Loop and three lines of lots ready for development, the western section largely already fenced between the lots and the coastal reserve) means that impacts to the wetland from works within the title will be negligible.

Under the Commonwealth *Environment Protection and Biodiversity Conservation Act 1999* an action will require approval from the minister if the action has, will have, or is likely to have, a significant impact on a matter of national environmental significance.

Matters of national environmental significance considered under the EPBCA include:

- listed threatened species and communities
- listed migratory species;
- Ramsar wetlands of international importance;
- Commonwealth marine environment;
- world heritage properties;
- national heritage places;
- the Great Barrier Reef Marine Park;
- nuclear actions; and
- a water resource, in relation to coal seam gas development and large coal mining development.

The relevant Commonwealth agency provides a policy statement titled *Matters of National Environmental Significance: Significant Impact Guidelines 1.1* (CofA 2013, herein the *Guidelines*), which provides overarching guidance on determining whether an action is likely to have a significant impact on a matter protected under the EPBCA.

The *Guidelines* define a **significant impact** as:

*“...an impact which is important, notable, or of consequence, having regard to its context or intensity. Whether or not an action is likely to have a significant impact depends upon the sensitivity, value, and quality of the environment which is impacted, and upon the intensity, duration, magnitude and geographic extent of the impacts”*

and note that:

*“...all of these factors [need to be considered] when determining whether an action is likely to have a significant impact on matters of national environmental significance”.*

The *Guidelines* provide advice on when a significant impact may be likely:

*“To be ‘likely’, it is not necessary for a significant impact to have a greater than 50% chance of happening; it is sufficient if a significant impact on the environment is a real or not remote chance or possibility.*

*If there is scientific uncertainty about the impacts of your action and potential impacts are serious or irreversible, the precautionary principle is applicable. Accordingly, a lack of scientific certainty*



## 8 (Lot 30) Spoonbill Loop, Sorell: Natural Values Statement

*about the potential impacts of an action will not itself justify a decision that the action is not likely to have a significant impact on the environment”.*

The *Guidelines* provide a set of Significant Impact Criteria, which are “intended to assist...in determining whether the impacts of [the] proposed action on any matter of national environmental significance are likely to be significant impacts”. It is noted that the criteria are “intended to provide general guidance on the types of actions that will require approval and the types of actions that will not require approval...[and]...not intended to be exhaustive or definitive”.

In relation to Ramsar wetlands, the *Guidelines* provide the following information:

### **Indirect and offsite impacts**

*When considering whether or not an action is likely to have a significant impact on a matter of national environmental significance it is relevant to consider all adverse impacts which result from the action, including indirect and offsite impacts.*

*Indirect and offsite impacts include:*

- a. ‘downstream’ or ‘downwind’ impacts, such as impacts on wetlands or ocean reefs from sediment, fertilisers or chemicals which are washed or discharged into river systems;*
- b. ‘upstream impacts’ such as impacts associated with the extraction of raw materials and other inputs which are used to undertake the action; and*
- c. ‘facilitated impacts’ which result from further actions (including actions by third parties) which are made possible or facilitated by the action. For example, the construction of a dam for irrigation water facilitates the use of that water by irrigators with associated impacts. Likewise, the construction of basic infrastructure in a previously undeveloped area may, in certain circumstances, facilitate the urban or commercial development of that area.*

*Consideration should be given to all adverse impacts that could reasonably be predicted to follow from the action, whether these impacts are within the control of the person proposing to take the action or not. Indirect impacts will be relevant where they are sufficiently close to the proposed action to be said to be a consequence of the action, and they can reasonably be imputed to be within the contemplation of the person proposing to take the action.*

*It may be helpful to consider the following:*

- ‘But for’ the proposed action would the indirect impacts occur?*
- Is the proposed action a ‘material and substantial’ cause of the indirect impacts?*
- Are the potential impacts of any subsequent or third party actions known, or would they be expected to be known, by the person proposing to take the action (particularly where the subsequent or third party actions are an intended outcome of the proposed action)?*

*If the answer to these questions is ‘yes’, then it is necessary to consider whether these impacts are likely to occur, and whether they are likely to have a significant impact on a matter of national environmental significance. If so, as much information as possible should be provided to assist the minister in determining whether the impacts are relevant, and whether approval under the EPBC Act is required.*

In specific respect to wetlands of internal importance (Ramsar), the *Guidelines* state:

*Approval is required for an action occurring within or outside a declared Ramsar wetland if the action has, will have, or is likely to have a significant impact on the ecological character of the Ramsar wetland.*

*An action is likely to have a significant impact on the ecological character of a declared Ramsar wetland if there is a real chance or possibility that it will result in:*

- areas of the wetland being destroyed or substantially modified*
- a substantial and measurable change in the hydrological regime of the wetland, for example, a substantial change to the volume, timing, duration and frequency of ground and surface water flows to and within the wetland*
- the habitat or lifecycle of native species, including invertebrate fauna and fish species, dependant upon the wetland being seriously affected*



## 8 (Lot 30) Spoonbill Loop, Sorell: Natural Values Statement

- a substantial and measurable change in the water quality of the wetland – for example, a substantial change in the level of salinity, pollutants, or nutrients in the wetland, or water temperature which may adversely impact on biodiversity, ecological integrity, social amenity or human health, or
- an invasive species that is harmful to the ecological character of the wetland being established (or an existing invasive species being spread) in the wetland.

RESPONSE: Based on the site assessment, I do not consider that any of these potential impacts are likely such that a significant impact is not anticipated.

Note that this statement does not constitute legal advice, and provides my interpretation of the provisions of the *Tasmanian Planning Scheme – Sorell Local Provisions Schedule*, which may not represent the views of Sorell Council. It is recommended that formal advice be sought from the relevant agency prior to acting on any aspect of this report.

Please do not hesitate to contact me further if additional information is required.

Kind regards



**Mark Wapstra**  
**Senior Scientist/Manager**





Wilson Multi,  
Lot 30 Spoonbill Loop,  
Sorell.

Detail Plan  
Lot 30

SCALE	CONTOUR INTERVAL
1:200 (@ A3)	0.1 metre
DATUM	File #
Horiz. MGA20	5727
Vert. A.H.D.	
Surveyed P.J.M.	Date 15-02-24
Autocad file	5727 Wilson Multi Lot 30 Spoonbill Loop
GeoCivil file	5727\Detail\1\project\5727d1g20

**James McEldowney Surveying**  
15 Ingram Street, South Hobart. 7004.  
Telephone (03) 62235236 Mobile 0418135442  
Email: mail@jmsurvey.com.au

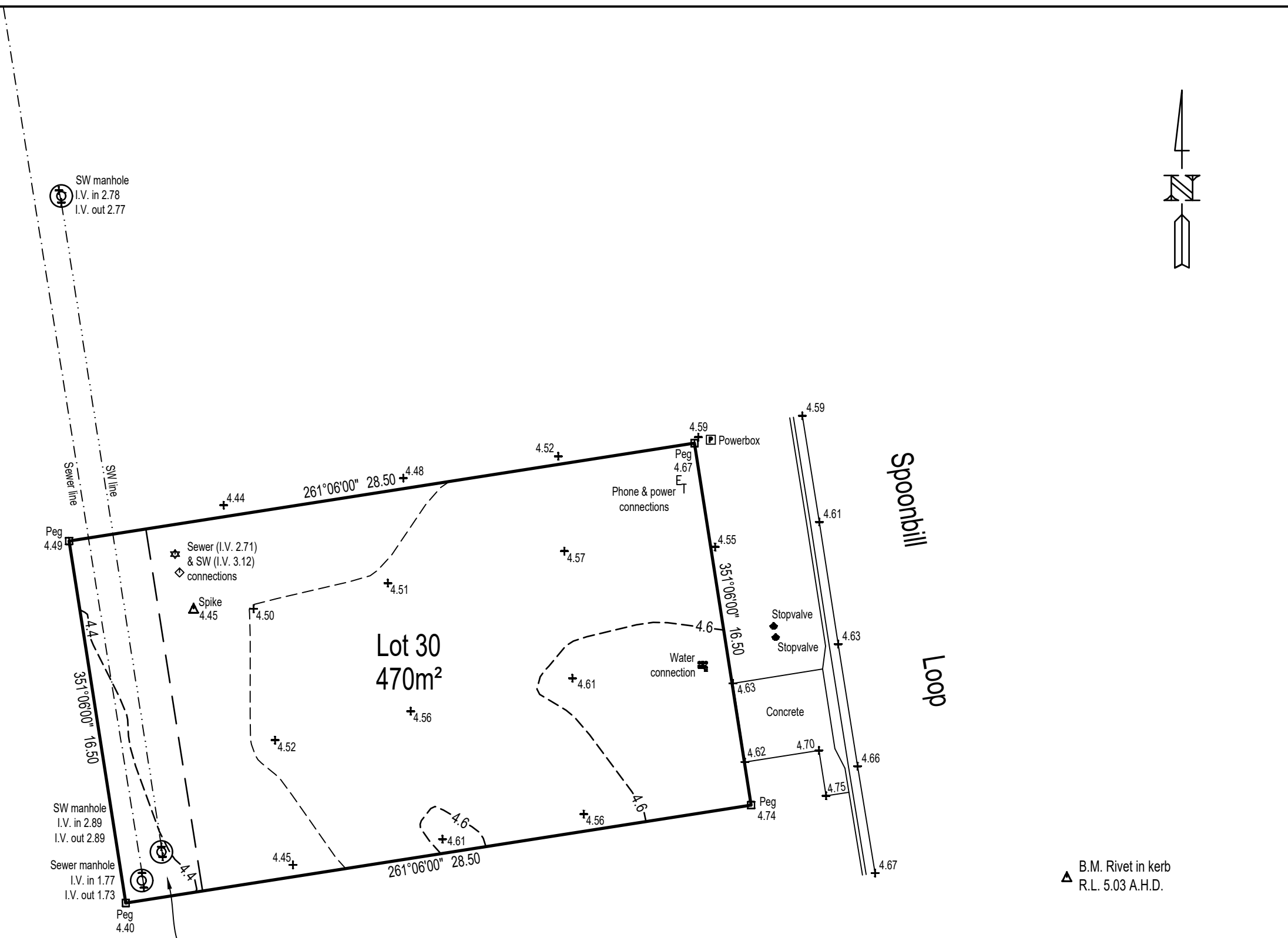

▲ B.M. Rivet in kerb  
R.L. 5.03 A.H.D.

**Sorell Council**  
Development Application: Development  
Application -Lot 30 Spoonbill Loop, Sorell - P1.pdf  
Plans Reference:P1  
Date Received:12/04/2024

**Note:-**  
Boundaries shown hereon are from preliminary plans.  
Before commencement of any building work boundaries shown hereon should be verified by comparison with the final registered title dimensions as obtained from the Lands Titles Office.  
James McEldowney Surveying accepts no responsibility for alterations made to preliminary plans prior to final registration.  
Do not remove this note from this or subsequent plans.

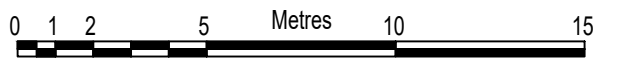



WH713965 - PROPOSED RESIDENCE  
 Lot 30, Spoonbill Loop,  
 SORELL

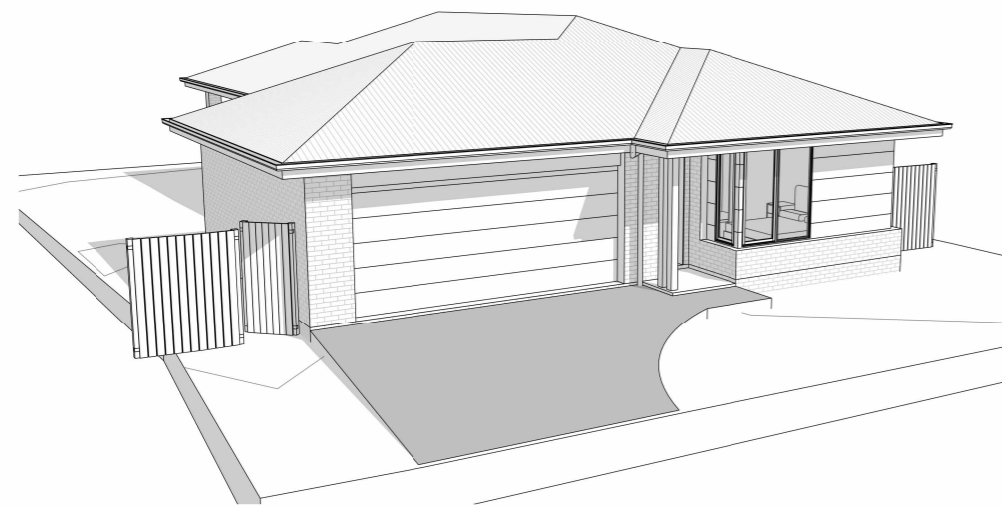

SHEET	DRAWING TITLE
01	SITE PLAN
01a	DRAINAGE PLAN
02	FLOOR PLAN
03	ELEVATIONS SHEET
03a	PERSPECTIVE VIEWS
03b	INTERNAL ELEVATIONS - KITCHEN
03c	INTERNAL ELEVATIONS - BATH
03d	INTERNAL ELEVATIONS - ENSUITE

**Sorell Council**  
 Development Application: Development  
 Application -Lot 30 Spoonbill Loop, Sorell - P1.pdf  
 Plans Reference:P1  
 Date Received:12/04/2024

DESIGN	YORK 14
FAÇADE	TEMPO

SITE IS NOT BUSHFIRE PRONE AREA AS PER TASMANIAN PLANNING SCHEME OVERLAY - SORELL.  
 No additional restrictions for construction methods / materials apply.

Notes • Builder to verify all dimensions and levels on site prior to commencement of work • All work to be carried out in accordance with the current National Construction Code. • All materials to be installed according to manufacturers specifications. • Do not scale from these drawings. • No changes permitted without consultation with designer.	Designer: ANOTHER PERSPECTIVE PTY LTD PO BOX 21 NEW TOWN LIC. NO. 685230609 (S. Turvey) Ph: (03) 6231 4122 Fx: (03) 6231 4166 Email: info@anotherperspective.com.au	Client / Project info PROPOSED RESIDENCE Lot 30, Spoonbill Loop, SORELL	Soil Classification: P Title Reference: TBC Floor Areas: 154.73m <sup>2</sup> Porch / Deck Areas: 16.23m <sup>2</sup> Wind Speed: N3 Climate Zone: 7 Alpine Zone: N/A Corrosion Environment: Medium Certified BAL: NOT BUSHFIRE PRONE Designed BAL: NOT BUSHFIRE PRONE (Refer to Standard Notes for Explanation)	COVER SHEET	
			Date 18 March 2024 Sheet Scale 00/03		

No.	Amendment	Date	Drawn	Checked	Sheet
		10 Apr. 24	ST	CK	01 - 03
		18 Mar. 24	ST	CK	01 - 03





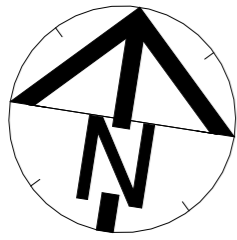

Where ag drain is < 1.5m from footing, the following engineering principles are required:

1. Ag drain to be capped with 300mm of clay to prevent ingress of surface run-off unless it is under a paving slab etc (ag drains are designed for removal of ground water, surface water should be dealt with separately).
2. Ag drain to have a minimum 1% fall to a grated pit which drains to the stormwater system.
3. Install a geotextile filter sock to the slotted drain, and enclose the whole drain in geofabric (to the underside of clay capping).
4. Provide additional grated pits / or inspection openings along the length of the ag drain and at the high point to make the effect of a blockage visible and enable a blockage to be cleared.

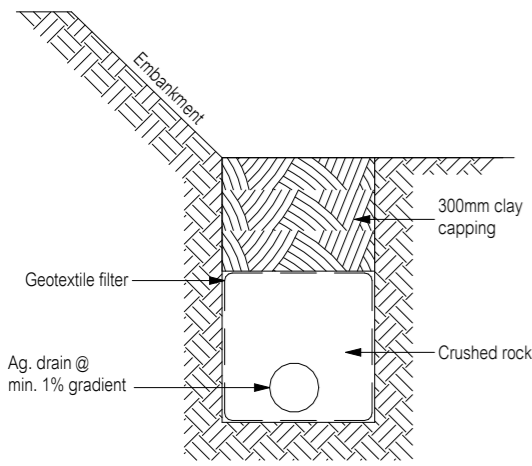

TYPICAL AG. DRAIN DETAIL (<1800 FROM HOUSE)  
Not to scale

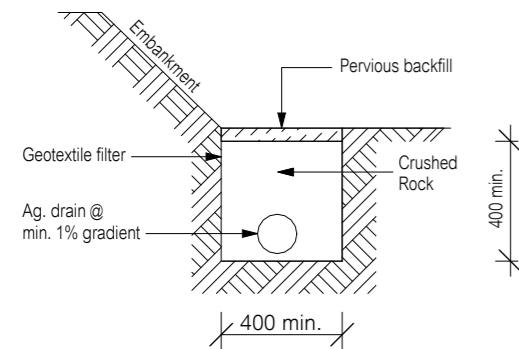

TYPICAL AG. DRAIN DETAIL (≥1800 FROM HOUSE)  
Not to scale

Note:-  
Boundaries shown hereon are from preliminary plans.  
Before commencement of any building work boundaries shown hereon should be verified by comparison with the final registered title dimensions as obtained from the Lands Titles Office.  
James McEldowney Surveying accepts no responsibility for alterations made to preliminary plans prior to final registration.  
Do not remove this note from this or subsequent plans.

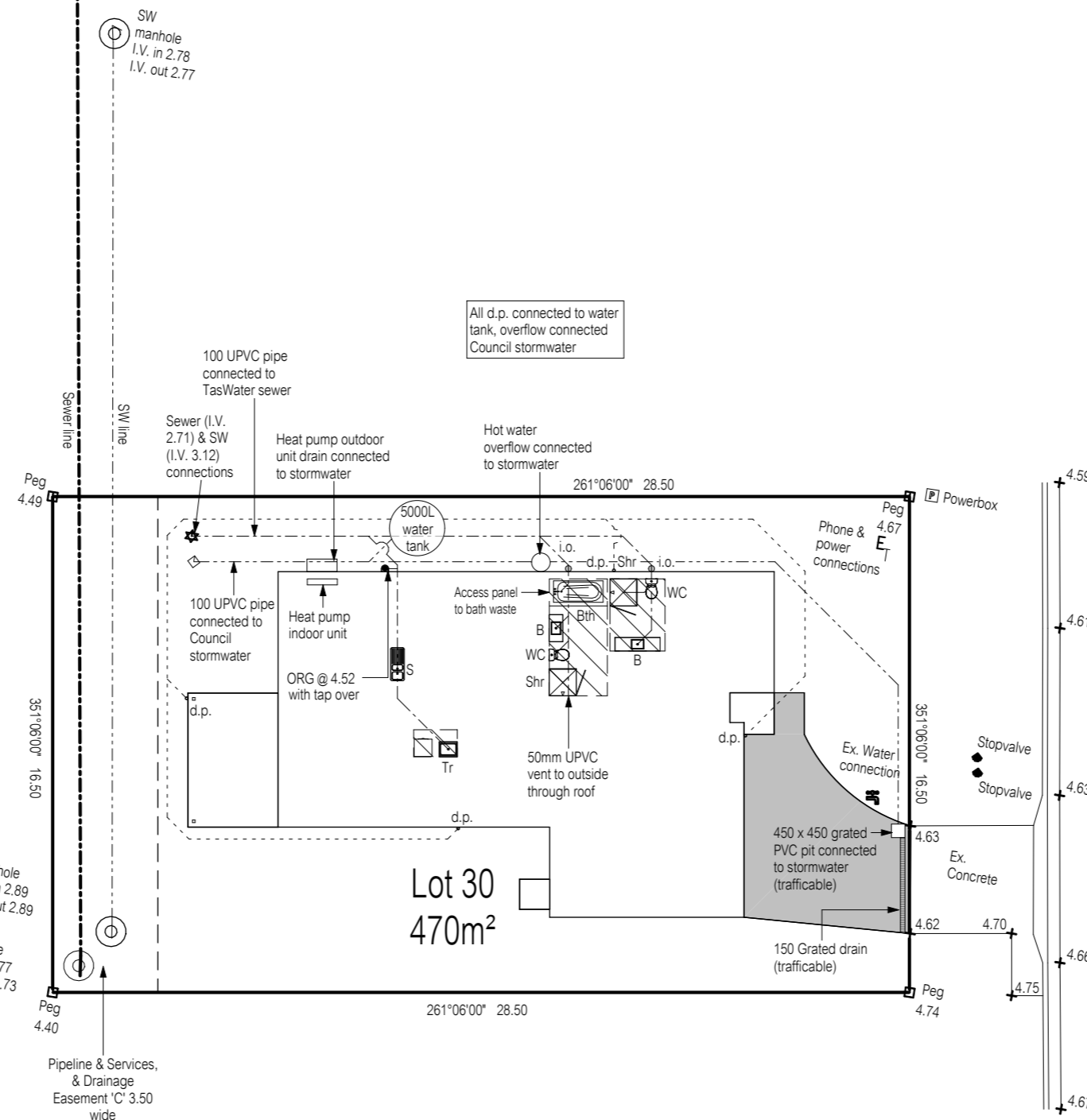

DRAINAGE LEGEND		
Abbreviation	Fixture	Min. Outlet Size
B	Basin	400
Bth	Bath	400
Shr	Shower	400 (Note 3)
S	Sink	500
Tr	Trough	400
WC	Water Closet Pan	1000
d.p.	Downpipe	900
ORG	Overflow Relief Gully	1000
FWG	Floor Waste Gully	650 (Note 2)

--- Sewer Line (1000 UPVC) (unless noted otherwise)  
--- Stormwater Line (1000 UPVC) (unless noted otherwise)  
--- Stormwater Line (1500 UPVC) (unless noted otherwise)

- NOTES:
1. Flexible connections are to be installed on any pipes emerging from beneath the building in accordance with AS2870 & AS/NZS3500.2:2021.
  2. Untrapped Bath tub pipe to connect to FWG if trap not accessible from below or access panel.
  3. 500 required for multiple shower heads.
  4. Showers to comply with N.C.C. 10.2.14.
  5. Falls to floor waste to be minimum 1:80 & maximum 1:50

**Sorell Council**  
Development Application: Development Application - Lot 30 Spoonbill Loop, Sorell - P1.pdf  
Plans Reference: P1  
Date Received: 12/04/2024

All works are to be in accordance with the Water Supply Code of Australia WSA 03-2011-3.1 Version 3.1 MRWA Edition V2.0 and Sewerage Code of Australia Melbourne Retail Water Agencies Code WSA 02-2014-3.1 MRWA Version 2.0 and TasWater's supplements to these codes.

ROOF DRAINAGE NOTE:  
Min. medium rectangular gutter & min. 900 downpipe specified as per N.C.C. part 7.4. These sizes and downpipe quantities are based on a max. roof catchment area of 70m²



Soil classification: P Refer to Soil Report for nominated founding depth and description of founding material. All Materials and construction to comply with AS/NZ3500 Part 2 & Part 3	Notes • Builder to verify all dimensions and levels on site prior to commencement of work • All work to be carried out in accordance with the current National Construction Code. • All materials to be installed according to manufacturers specifications. • Do not scale from these drawings. • No changes permitted without consultation with designer.	Designer: ANOTHER PERSPECTIVE PTY LTD PO BOX 21 NEW TOWN LIC. NO. 685230609 (S. Turvey) Ph: (03) 6231 4122 Fx: (03) 6231 4166 Email: info@anotherperspective.com.au	Client / Project info PROPOSED RESIDENCE Lot 30, Spoonbill Loop, SORELL		DRAINAGE PLAN					
		<table border="1"> <tr> <td>Drawn</td> <td>ST</td> <td>WH713965</td> </tr> <tr> <td>Date</td> <td>10 April 2024</td> <td>Sheet</td> </tr> <tr> <td>Scale</td> <td>1:200</td> <td rowspan="2">01a/03</td> </tr> </table>			Drawn	ST	WH713965	Date	10 April 2024	Sheet
Drawn	ST	WH713965								
Date	10 April 2024	Sheet								
Scale	1:200	01a/03								
No.	Date		Int.	Amendment changes as per cover sheet						

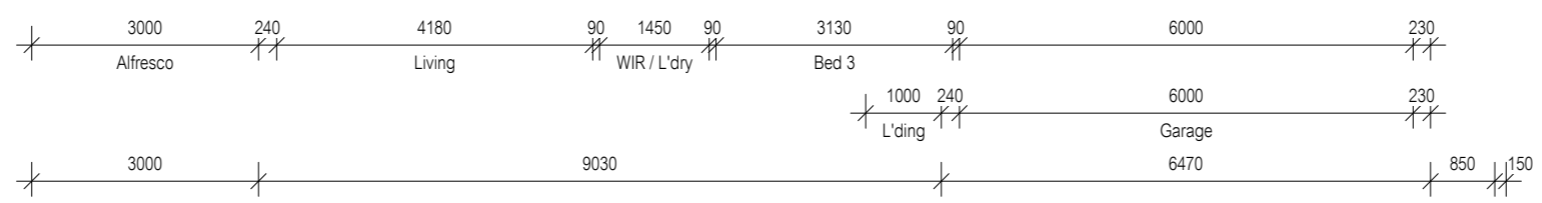
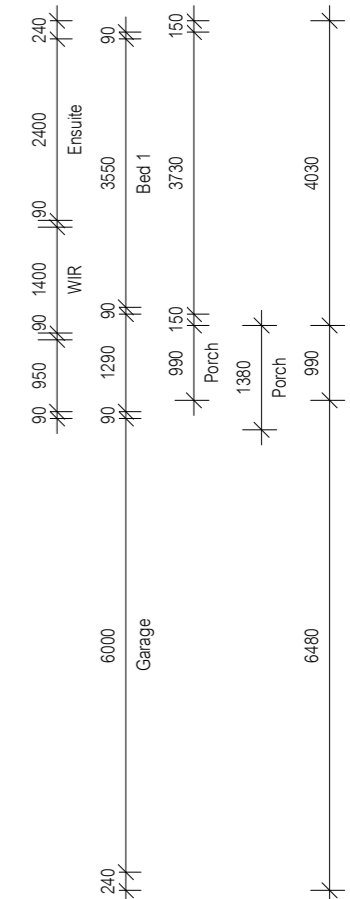
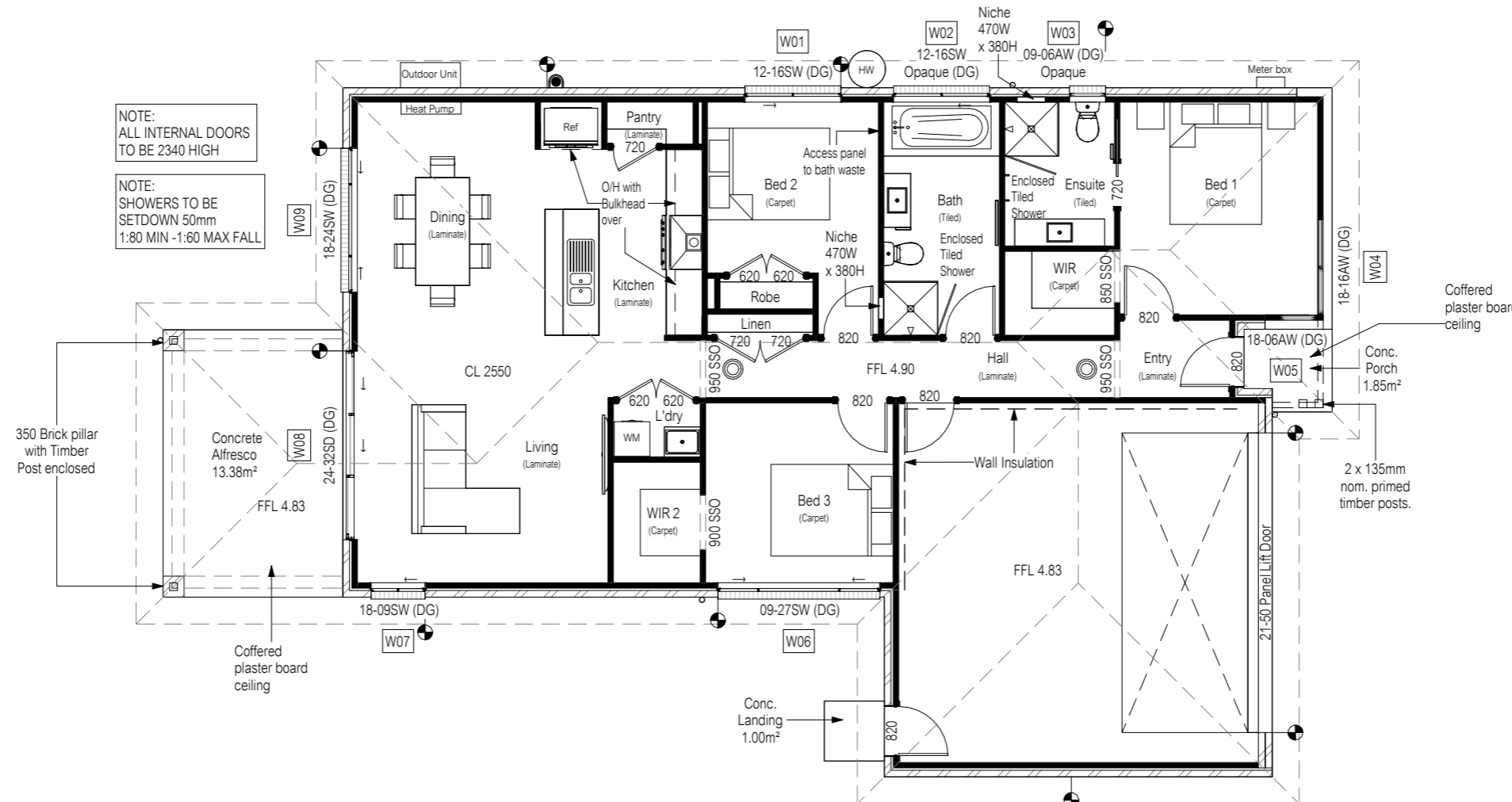
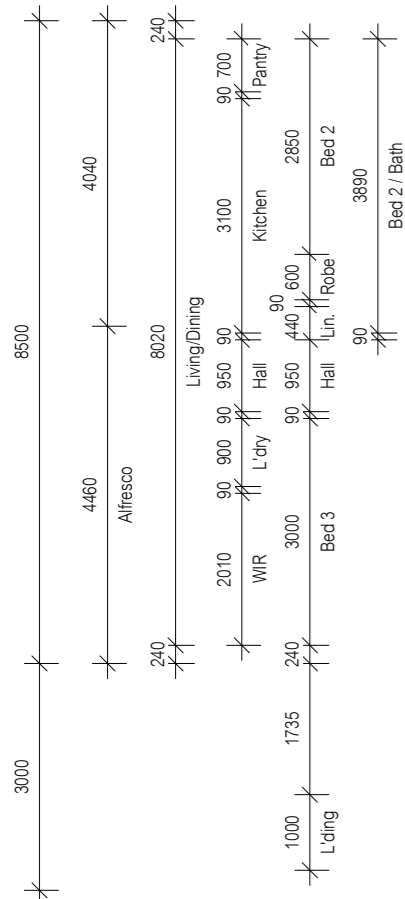
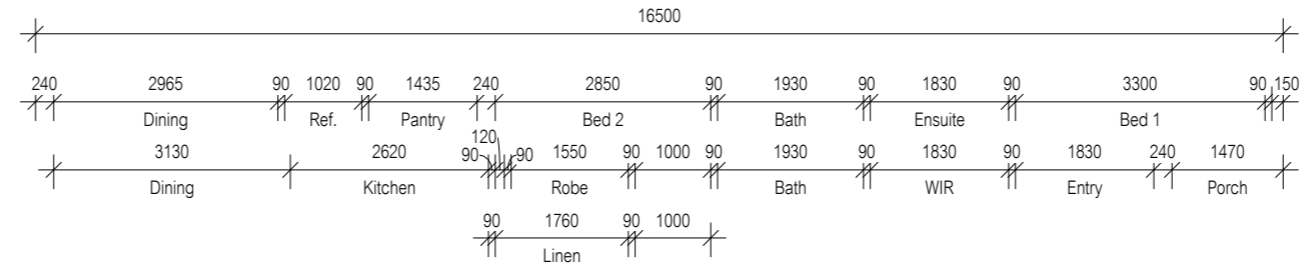
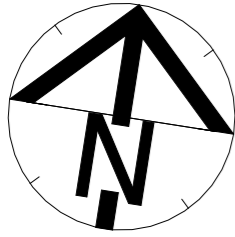

**Sorell Council**  
 Development Application: Development Application - Lot 30 Spoonbill Loop, Sorell - P1.pdf  
 Plans Reference: P1  
 Date Received: 12/04/2024



Floor Area = 154.73m <sup>2</sup> ● Articulation joints ● Smoke Alarm (interconnected where more than 1)	All window sizes to be checked and/or confirmed on site prior to ordering glazing units	<b>Notes</b> • Builder to verify all dimensions and levels on site prior to commencement of work • All work to be carried out in accordance with the current National Construction Code. • All materials to be installed according to manufacturers specifications. • Do not scale from these drawings. • No changes permitted without consultation with designer.	<b>Designer:</b> ANOTHER PERSPECTIVE PTY LTD PO BOX 21 NEW TOWN LIC. NO. 685230609 (S. Turvey) Ph: (03) 6231 4122 Fx: (03) 6231 4166 Email: info@anotherperspective.com.au	<b>Client / Project info</b> PROPOSED RESIDENCE Lot 30, Spoonbill Loop, SORELL		<b>FLOOR PLAN</b>	
			Drawn ST WH713965 Date 18 March 2024 Sheet Scale 1:100 Copyright © 02/03				

No.	Date	Int.	Amendment changes as per cover sheet
-----	------	------	--------------------------------------

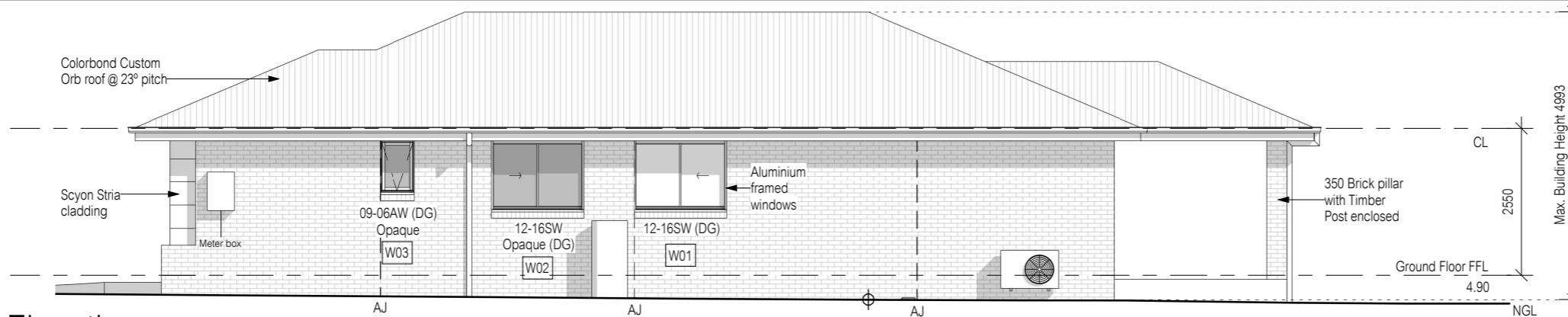

North Elevation

Material	Colour
Colorbond Roof	tbc
Face Brick	tbc
FC Sheet	tbc

All lightweight cladding to be installed to manufacturer's guidelines. Refer to manufacturer's documentation.

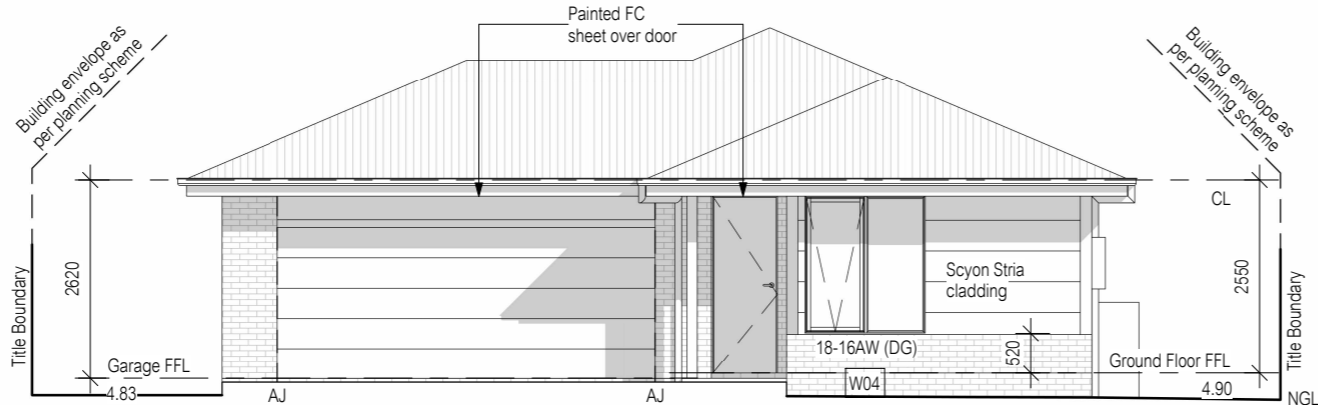

East Elevation

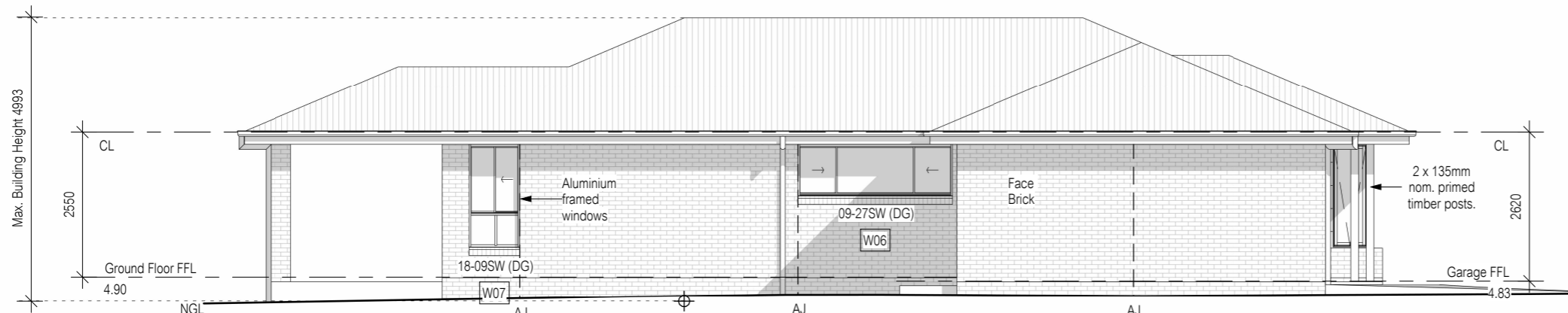

South Elevation



West Elevation

**Sorell Council**  
 Development Application: Development Application -Lot 30 Spoonbill Loop, Sorell - P1.pdf  
 Plans Reference:P1  
 Date Received:12/04/2024

No.	Date	Int.

Amendment changes as per cover sheet

All window sizes to be checked and/or confirmed on site prior to ordering glazing units

LEGEND:  
 AJ - Articulation Joint  
 BV - Brick Vent

Shadows shown for stylisation purposes only

- Notes
- Builder to verify all dimensions and levels on site prior to commencement of work
  - All work to be carried out in accordance with the current National Construction Code.
  - All materials to be installed according to manufacturers specifications.
  - Do not scale from these drawings.
  - No changes permitted without consultation with designer.

Designer:  
 ANOTHER PERSPECTIVE PTY LTD  
 PO BOX 21  
 NEW TOWN  
 LIC. NO. 685230609 (S. Turvey)  
 Ph: (03) 6231 4122  
 Fx: (03) 6231 4166  
 Email:  
 info@anotherperspective.com.au

Client / Project info  
 PROPOSED RESIDENCE  
 Lot 30, Spoonbill Loop,  
 SORELL



ELEVATIONS SHEET		
Drawn	ST	WH713965
Date	18 March 2024	Sheet
Scale	1:100	03/03
Copyright ©		

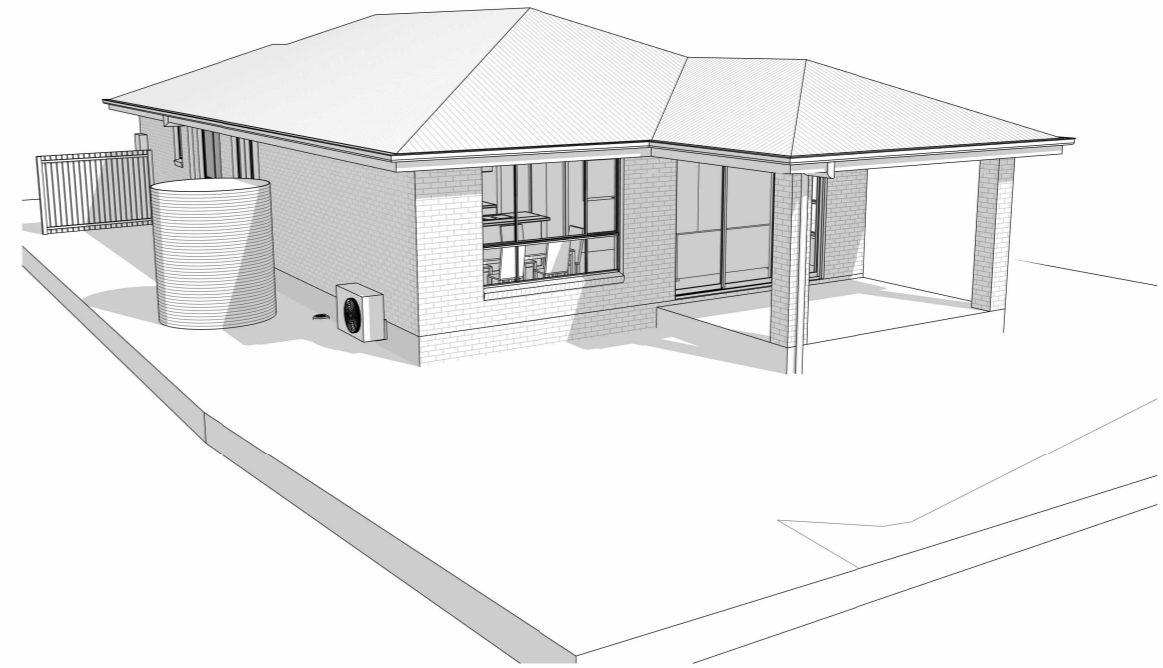
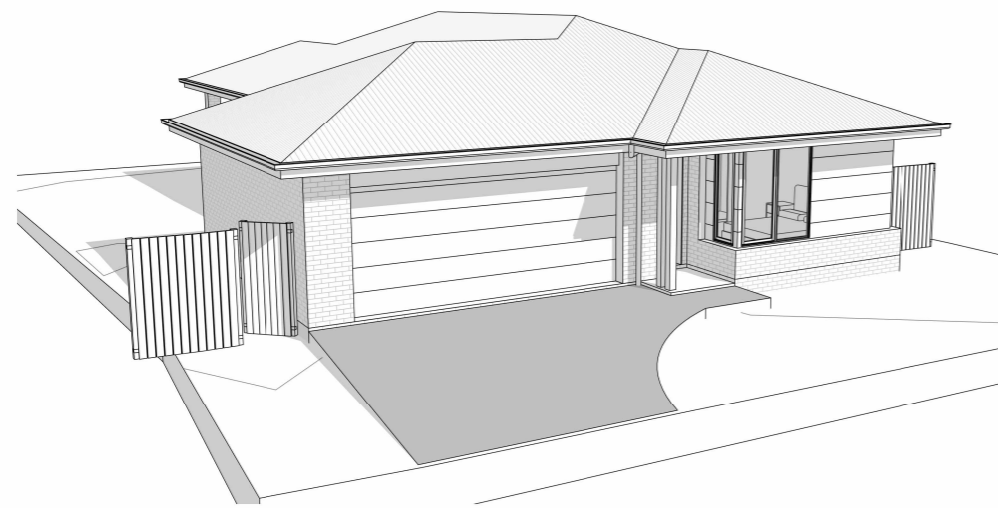

**Sorell Council**  
 Development Application: Development  
 Application -Lot 30 Spoonbill Loop, Sorell - P1.pdf  
 Plans Reference:P1  
 Date Received:12/04/2024

No.	Date	Int.	Amendment changes as per cover sheet	Shadows shown for stylisations purpose only	Notes • Builder to verify all dimensions and levels on site prior to commencement of work • All work to be carried out in accordance with the current National Construction Code. • All materials to be installed according to manufacturers specifications. • Do not scale from these drawings. • No changes permitted without consultation with designer.	Designer: ANOTHER PERSPECTIVE PTY LTD PO BOX 21 NEW TOWN LIC. NO. 685230609 (S. Turvey) Ph: (03) 6231 4122 Fx: (03) 6231 4166 Email: info@anotherperspective.com.au	Client / Project info PROPOSED RESIDENCE Lot 30, Spoonbill Loop, SORELL		PERSPECTIVE VIEWS	
						Drawn _____ ST WH713965 Date 18 March 2024 Sheet Scale _____ Copyright ©			03a/03	

**LEGEND:**  
MWS - MICROWAVE SPACE  
DWS - DISHWASHER SPACE  
RS - REFRIGERATOR SPACE

**NOTE:**  
- DIMENSIONS ARE FROM STUD WALL - NOT FINISHED SURFACES

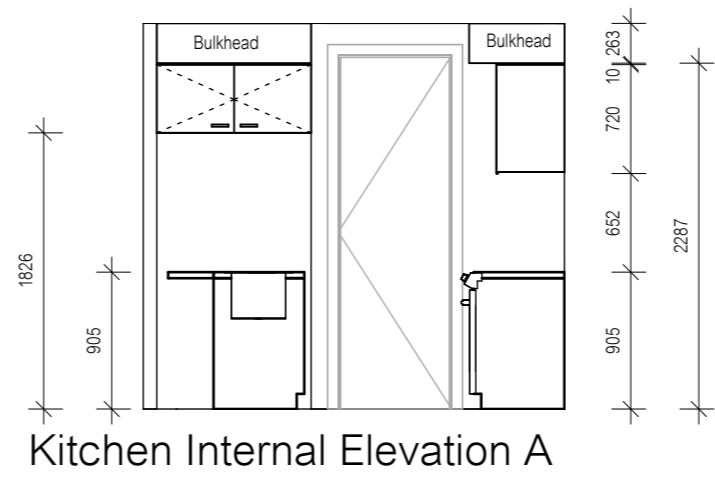

Kitchen Internal Elevation A

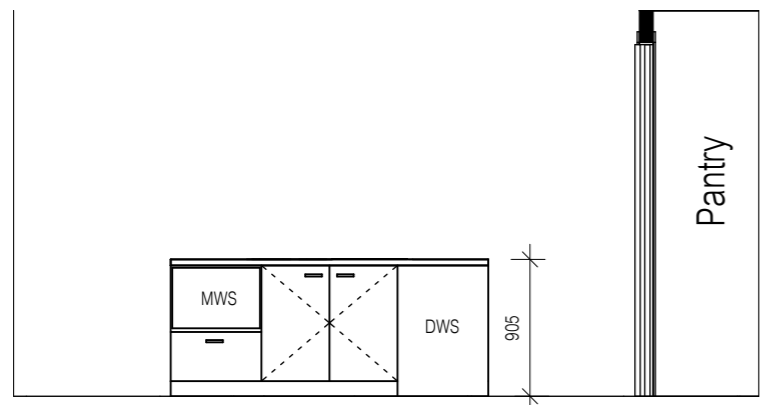

Kitchen Internal Elevation D

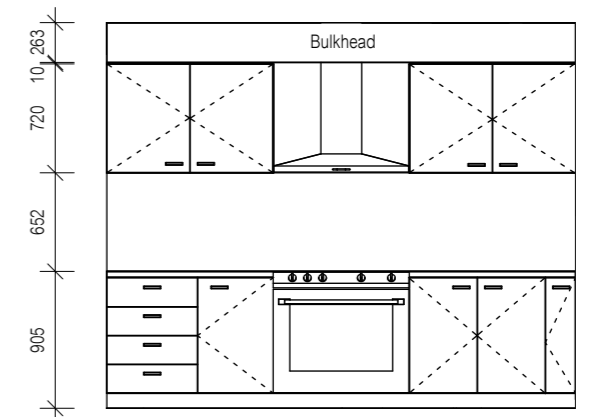
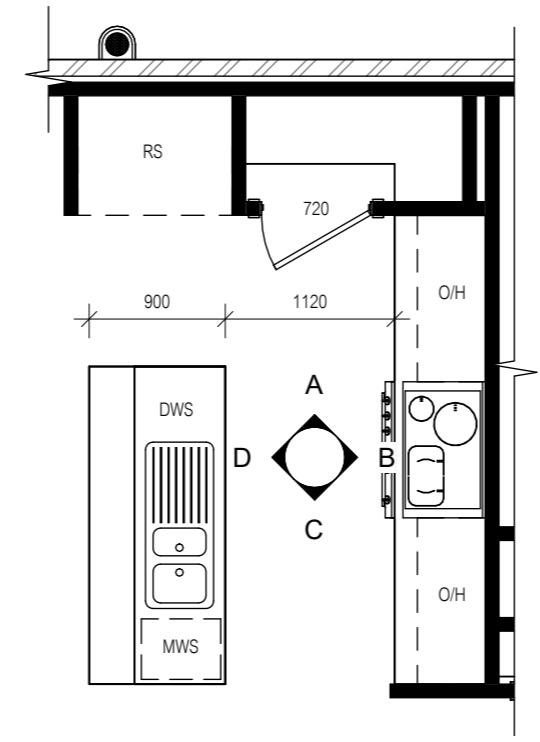

Kitchen Internal Elevation B

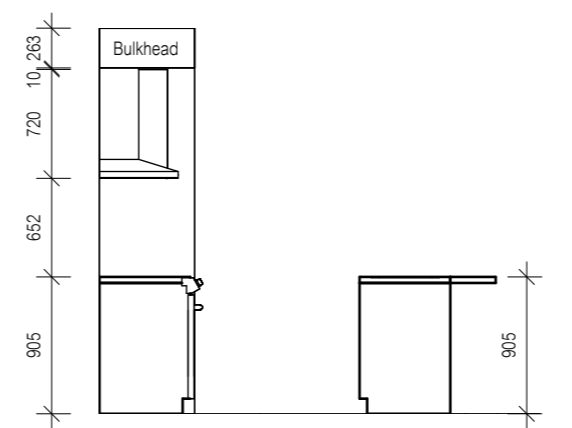

Kitchen Internal Elevation C

**Sorell Council**  
Development Application: Development Application -Lot 30 Spoonbill Loop, Sorell - P1.pdf  
Plans Reference:P1  
Date Received:12/04/2024

- Notes
- Builder to verify all dimensions and levels on site prior to commencement of work
  - All work to be carried out in accordance with the current National Construction Code.
  - All materials to be installed according to manufacturers specifications.
  - Do not scale from these drawings.
  - No changes permitted without consultation with designer.

Designer:  
ANOTHER PERSPECTIVE PTY LTD  
PO BOX 21  
NEW TOWN  
LIC. NO. 685230609 (S. Turvey)  
Ph: (03) 6231 4122  
Fx: (03) 6231 4166  
Email:  
info@anotherperspective.com.au

Client / Project info  
PROPOSED RESIDENCE  
Lot 30, Spoonbill Loop,  
SORELL



INTERNAL ELEVATIONS - KITCHEN		
Drawn	ST	WH713965
Date	18 March 2024	Sheet
Scale	1:50	03b/03
Copyright ©		

No.	Date	Int.	Amendment changes as per cover sheet
-----	------	------	--------------------------------------

**LEGEND**

- RSHR - RAIL SHOWER
- ROSE - SHOWER ROSE
- ELBW - SHOWER ELBOW CONNECTION
- MIX - MIXER TAP
- HT - HOT TAP
- CT - COLD TAP
- HS - HOB SPOUT
- WS - WALL SPOUT
- SC - STOP COCK
- TRH - TOILET ROLL HOLDER
- TR-S - TOWEL RAIL-SINGLE
- TR-D - TOWEL RAIL-DOUBLE
- TL - TOWEL LADDER
- TR - TOWEL RACK
- TMB - TUMBLER HOLDER
- RNG - TOWEL RING
- RH - ROBE HOOK
- SHLF - SHELF

**NOTE:**  
DIMENSIONS ARE FROM STUD WALL - NOT FINISHED SURFACES

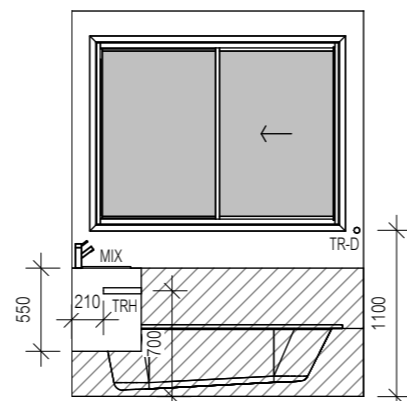

Bath Internal Elevation A

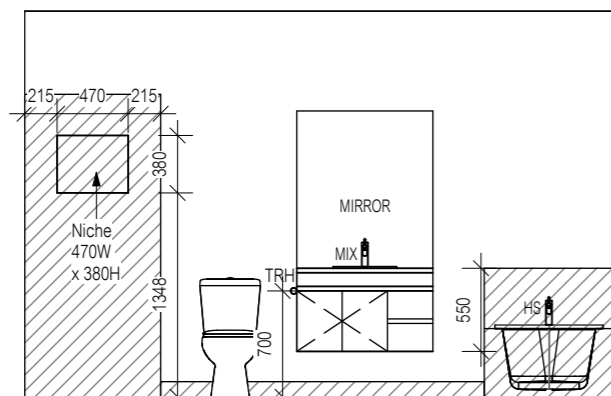

Bath Internal Elevation D

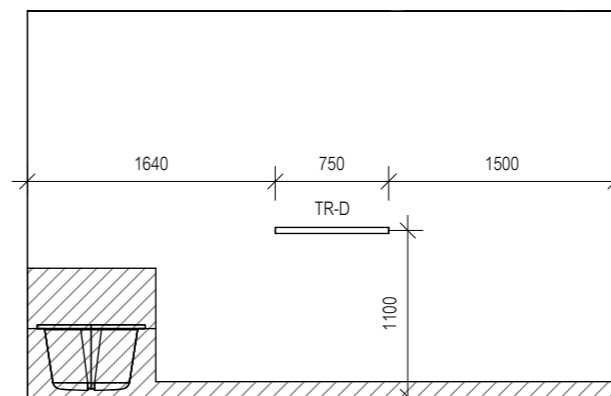
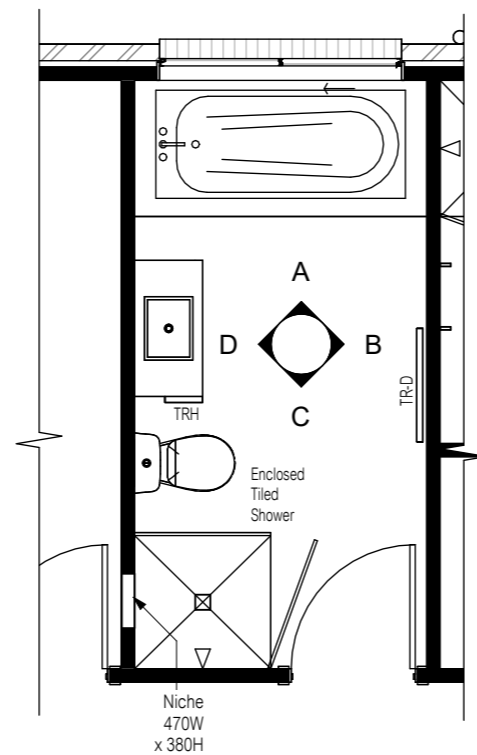

Bath Internal Elevation B

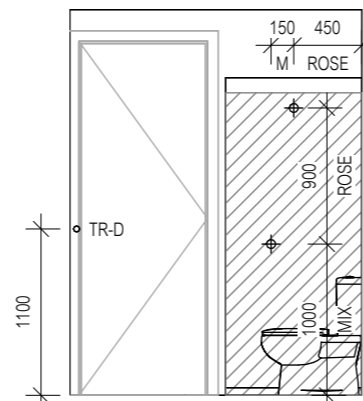

Bath Internal Elevation C

**Sorell Council**  
 Development Application: Development Application - Lot 30 Spoonbill Loop, Sorell - P1.pdf  
 Plans Reference: P1  
 Date Received: 12/04/2024

No.	Date	Int.	Amendment changes as per cover sheet
-----	------	------	--------------------------------------

**Notes**

- Builder to verify all dimensions and levels on site prior to commencement of work
- All work to be carried out in accordance with the current National Construction Code.
- All materials to be installed according to manufacturers specifications.
- Do not scale from these drawings.
- No changes permitted without consultation with designer.

**Designer:**  
 ANOTHER PERSPECTIVE PTY LTD  
 PO BOX 21  
 NEW TOWN  
 LIC. NO. 685230609 (S. Turvey)  
 Ph: (03) 6231 4122  
 Fx: (03) 6231 4166  
 Email:  
 info@anotherperspective.com.au

**Client / Project info**  
 PROPOSED RESIDENCE  
 Lot 30, Spoonbill Loop,  
 SORELL



**INTERNAL ELEVATIONS - BATH**

Drawn ST WH713965

Date 18 March 2024 Sheet

Scale 1:50

Copyright ©

03c/03

LEGEND	
RSHR	- RAIL SHOWER
ROSE	- SHOWER ROSE
ELBW	- SHOWER ELBOW CONNECTION
MIX	- MIXER TAP
HT	- HOT TAP
CT	- COLD TAP
HS	- HOB SPOUT
WS	- WALL SPOUT
SC	- STOP COCK
TRH	- TOILET ROLL HOLDER
TR-S	- TOWEL RAIL-SINGLE
TR-D	- TOWEL RAIL-DOUBLE
TL	- TOWEL LADDER
TR	- TOWEL RACK
TMB	- TUMBLER HOLDER
RNG	- TOWEL RING
RH	- ROBE HOOK
SHLF	- SHELF

**NOTE:**  
DIMENSIONS ARE FROM STUD WALL - NOT FINISHED SURFACES

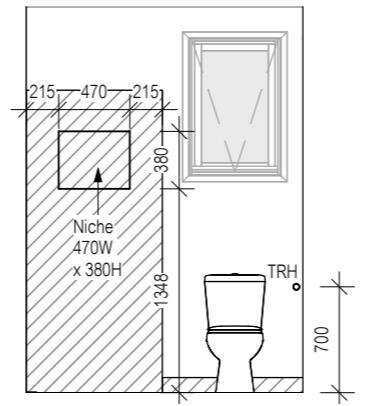

Ensuite Internal Elevation A

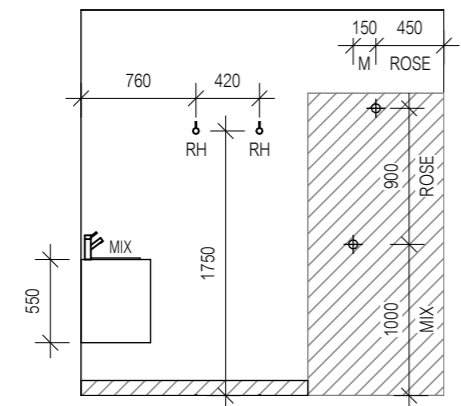

Ensuite Internal Elevation D

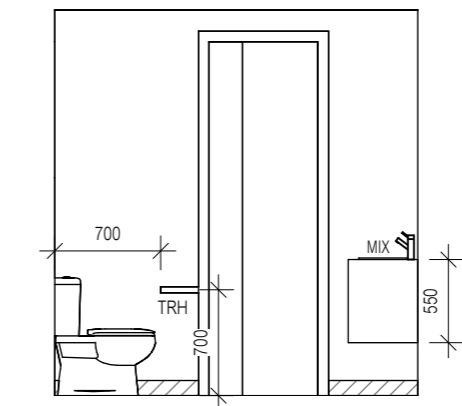
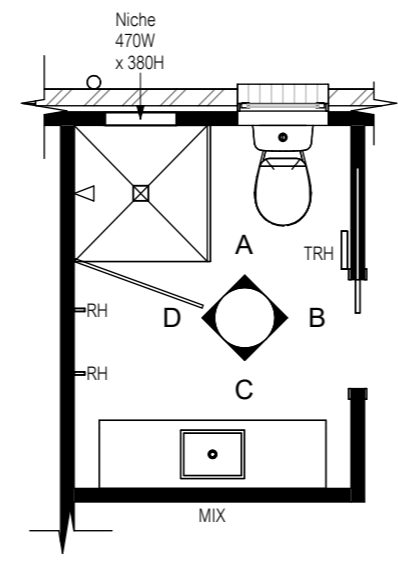

Ensuite Internal Elevation B

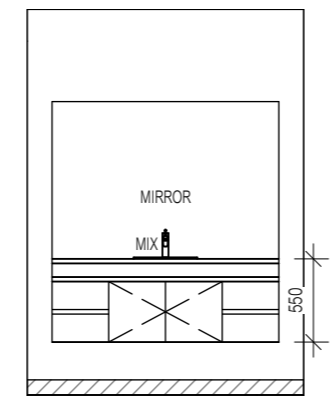

Ensuite Internal Elevation C

**Sorell Council**  
 Development Application: Development Application - Lot 30 Spoonbill Loop, Sorell - P1.pdf  
 Plans Reference: P1  
 Date Received: 12/04/2024

Notes

- Builder to verify all dimensions and levels on site prior to commencement of work
- All work to be carried out in accordance with the current National Construction Code.
- All materials to be installed according to manufacturers specifications.
- Do not scale from these drawings.
- No changes permitted without consultation with designer.

Designer:  
 ANOTHER PERSPECTIVE PTY LTD  
 PO BOX 21  
 NEW TOWN  
 LIC. NO. 685230609 (S. Turvey)  
 Ph: (03) 6231 4122  
 Fx: (03) 6231 4166  
 Email:  
 info@anotherperspective.com.au

Client / Project info  
 PROPOSED RESIDENCE  
 Lot 30, Spoonbill Loop,  
 SORELL



INTERNAL ELEVATIONS - ENSUITE		
Drawn	ST	WH713965
Date	18 March 2024	Sheet
Scale	1:50	03d/03
Copyright ©		

No.	Date	Int.	Amendment changes as per cover sheet

LEGEND (W = Wattage e.g. 35W = 35 Watts.)

- STANDARD CEILING LIGHT POINT (30W)
- DOWNLIGHT POINT (UNVENTED) (35W)
- ✱ LED DOWNLIGHT POINT (10W) SUITABLE FOR & FITTED WITH INSULATION OVER. (IC RATED)
- PENDANT LIGHT (30W)
- WALL LIGHT POINT (30W)
- 2 x 900mm FLUORESCENT LIGHT POINT (36W)
- 2 x SLIM T5 900mm FLUORESCENT LIGHT POINT (28W)
- △ SINGLE POWER POINT
- ◐ DOUBLE POWER POINT
- ◑ DOUBLE POWER POINT WITH USB
- ◒ WATER PROOF POWER POINT
- ⊙ MAINS POWERED SMOKE ALARM (INTERCONNECTED WHERE MORE THAN 1)
- ⊞ FAN / HEATER / LIGHT (8W) (VENT IN ACCORDANCE WITH N.C.C. 10.8.2)
- ⊚ TV CONNECTION POINT
- ▽ NBN/TELEPHONE CONNECTION POINT
- ⊚ SENSOR LIGHT
- ⊚ EXHAUST FAN (VENT IN ACCORDANCE WITH N.C.C. 10.8.2)
- ⊚ FLOOD LIGHT
- ⊚ CAT 6 CONNECTION POINT
- ▶ TREAD LIGHTS (2W)
- ⊚ DUCTED VACUUM POINT
- ⊚ SECURITY SYSTEM KEYPAD
- ⊚ SECURITY SYSTEM SENSOR

ALL EXHAUST FANS:  
 25 L/s for a bathroom or sanitary compartment, 40 L/s for a kitchen or laundry. Exhaust from a kitchen, kitchen range hood, bathroom, sanitary compartment, or laundry must be discharged directly or via a shaft or duct to outdoor air.

Where no external ventilation / windows provided, exhaust fans to wet areas/ laundry to be fitted with a run on timer. 20mm gap base of door to comply with N.C.C. 10.8.2 (5)(a).

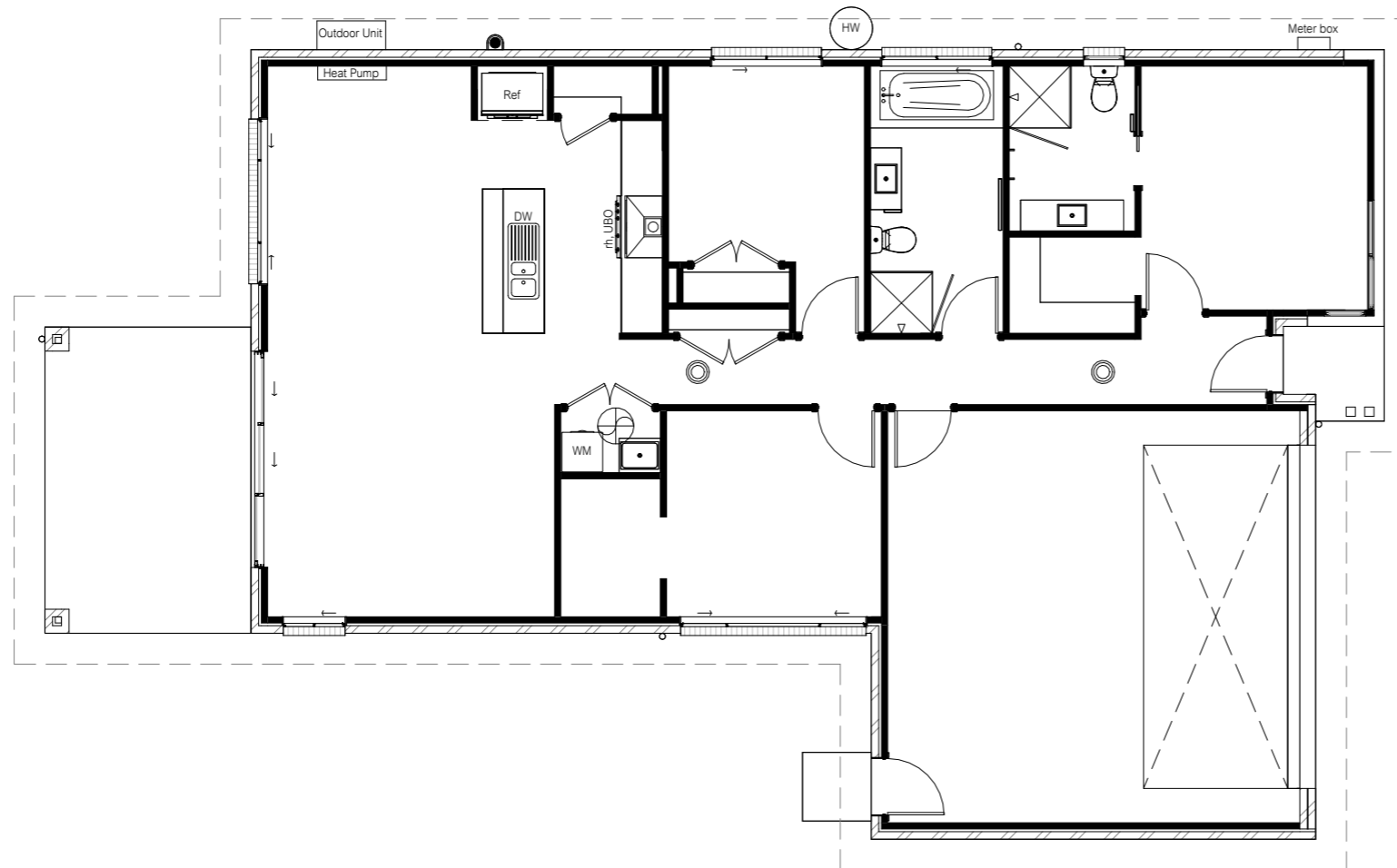

**Sorell Council**  
 Development Application: Development Application -Lot 30 Spoonbill Loop, Sorell - P1.pdf  
 Plans Reference:P1  
 Date Received:12/04/2024

		<p>Notes</p> <ul style="list-style-type: none"> <li>Builder to verify all dimensions and levels on site prior to commencement of work</li> <li>All work to be carried out in accordance with the current National Construction Code.</li> <li>All materials to be installed according to manufacturers specifications.</li> <li>Do not scale from these drawings.</li> <li>No changes permitted without consultation with designer.</li> </ul>	<p>Designer:</p> <p>ANOTHER PERSPECTIVE PTY LTD          PO BOX 21          NEW TOWN          LIC. NO. 685230609 (S. Turvey)          Ph: (03) 6231 4122          Fx: (03) 6231 4166          Email:          info@anotherperspective.com.au</p>	<p>Client / Project info</p> <p>PROPOSED RESIDENCE          Lot 30, Spoonbill Loop,          SORELL</p>		<p><b>ELECTRICAL PLAN</b></p> <table border="1" style="width: 100%; border-collapse: collapse;"> <tr> <td>Drawn</td> <td style="text-align: right;">ST</td> <td>WH713965</td> </tr> <tr> <td>Date</td> <td style="text-align: right;">18 March 2024</td> <td>Sheet</td> </tr> <tr> <td>Scale</td> <td style="text-align: right;">1:100</td> <td></td> </tr> </table> <p style="font-size: 2em; font-weight: bold; text-align: right;">09/03</p>	Drawn	ST	WH713965	Date	18 March 2024	Sheet	Scale	1:100	
Drawn	ST	WH713965													
Date	18 March 2024	Sheet													
Scale	1:100														
<table border="1" style="width: 100%; border-collapse: collapse;"> <tr> <th style="width: 10%;">No.</th> <th style="width: 10%;">Date</th> <th style="width: 10%;">Int.</th> <th style="width: 70%;">Amendment changes as per cover sheet</th> </tr> <tr> <td> </td> <td> </td> <td> </td> <td> </td> </tr> </table>	No.	Date	Int.	Amendment changes as per cover sheet											
No.	Date	Int.	Amendment changes as per cover sheet												





# Lighting

## Class 1 & 10a buildings



**Building name/description**  
WH713966 - PROPOSED RESIDENCE, Lot 62, 31 Sunningdale Close, MIDWAY POINT

**Number of rows preferred in table below**  (as currently displayed)

**2. ENTER CLASSIFICATION**

Separate aggregate allowances are calculated for Class 1 cases; for a verandah or balcony; or for a Class 10 building. The % of allowance used' outcomes refer to these aggregate allowances.

ID	Description	Type of space	Floor area of the space	Design lamp or illumination power load	Location	Adjustment factor			CALCULATED OUTCOMES		
						Adjustment factors	Dimming % area	Dimming % of full power	Design lumen depreciation factor	Lamp or illumination power density	System share of % of aggregate allowance used
1	PANTRY	Other	1.0 m <sup>2</sup>								
2	LIVING	Living room	18.9 m <sup>2</sup>								
3	KITCHEN	Kitchen	9.4 m <sup>2</sup>								
4	BED 2	Bedroom	10.1 m <sup>2</sup>								
5	BATH	Bathroom	7.5 m <sup>2</sup>								
6	ENSUITE	Bathroom	4.4 m <sup>2</sup>								
7	BED 1	Bedroom	11.7 m <sup>2</sup>								
8	BED 3	Bedroom	9.4 m <sup>2</sup>								
9	WIR	Other	2.6 m <sup>2</sup>								
10	DINING	Lounge room	11.5 m <sup>2</sup>								
11	WIR 2	Other	2.9 m <sup>2</sup>								
12	HALL	Corridor	7.3 m <sup>2</sup>								
13	L'DRY	Laundry	1.3 m <sup>2</sup>								
14	ENTRY	Corridor	2.4 m <sup>2</sup>								
15	GARAGE	Other	36.0 m <sup>2</sup>								
16	ALFRESCO	Verandah or balcony	13.4 m <sup>2</sup>								

149.7 m<sup>2</sup>

#VALUE!  
#VALUE!  
#VALUE!

#VALUE!

**IMPORTANT NOTICE AND DISCLAIMER IN RESPECT OF THIS LIGHTING CALCULATOR**

By accessing or using this calculator, you agree to the following: While care has been taken in the preparation of this calculator, it may not be complete or up-to-date. You can ensure that you are using a complete and up-to-date version by checking the Australian Building Codes Board website ([abcb.gov.au](http://abcb.gov.au)). The Australian Building Codes Board, the Commonwealth of Australia and States and Territories of Australia do not accept any liability, including liability for negligence, for any loss (howsoever caused), damage, injury, expense or cost incurred by any person as a result of accessing, using or relying upon this publication, to the maximum extent permitted by law. No representation or warranty is made or given as to the currency, accuracy, reliability, merchantability, fitness for any purpose or completeness of this publication or any information which may appear on any linked websites, or in other linked information sources, and all such representations and warranties are excluded to the extent permitted by law. This calculator is not legal or professional advice. Persons rely upon this calculator entirely at their own risk and must take responsibility for assessing the relevance and accuracy of the information in relation to their particular circumstances.



© Commonwealth of Australia and the States and Territories of Australia 2023, published by the Australian Building Codes Board. The material in this publication is licensed under a Creative Commons Attribution—4.0 International licence, with the exception of third party materials and any trade marks. It is provided for general information only and without warranties of any kind. More information on this CC BY licence is



Development Application: Development Application -Lot 30 Spoonbill Loop, Sorell - P1.pdf

Plans Reference:P1  
Date Received:12/04/2024

WINDOW MANUFACTURER:  
(?????WINDOW TYPE CHANGE????)

LEGEND:  
SW = Sliding Window, AW = Awning Window, SD = Sliding door, FD = French Door,  
BRPG = Bushfire Rated Privacy Glass  
NOTE: Window tags including (DG) are to be Double Glazed, otherwise they are to be single glazed.

NOTE:  
Windows supplied MUST HAVE Uw better and or equal to stated figures and SHGC within +/- 5% of stated figures.  
Windows labelled YES in "Restricted/protected" column to comply with N.C.C. 11.3.7 & 11.3.8  
\* - Glass specification changed to comply with Bushfire requirements (Refer to Sheet ---)

WINDOW NUMBER	SIZE / TYPE	ID	Uw	SHGC	RESTRICTED
W01	12-16SW (DG)				
W02	12-16SW Opaque (DG)				
W03	09-06AW (DG) Opaque				
W04	18-16AW (DG)				
W05	18-06AW (DG)				
W06	09-27SW (DG)				
W07	18-09SW (DG)				
W08	24-32SD (DG)				
W09	18-24SW (DG)				

INSULATION SCHEDULE	
Area	Insulation Details
Roof	Sarking (vapour permeable) OR R1.3 Anticon Sarking
Ceiling	R?? bulk insulation (or equivalent) excluding GARAGE
Walls (external)	R?? bulk insulation (or equivalent) with 1 layer sisalation (vapour permeable). Sisalation only to GARAGE
Walls (Internal)	N/A or R?? bulk insulation (or equivalent) to internal walls adjacent to GARAGE / SUBFLOOR / ROOFSPACE
Floors	R?? bulk insulation (or equivalent) to all timber floors

NOTE:  
Clearance is required for uncompressed installation of bulk insulation and timbers should be sized accordingly.  
Bulk insulation thicknesses vary depending on manufacturer and should be selected accordingly, and installed to manufacturer's specification.  
Min. 20mm clearance required between roofing and vapour permeable sarking (i.e. batten over sarking OR sarking over batten + vented batten)  
Min. 25mm air gap above bulk insulation into roof space.  
Where solar tubes are located, diffusers are to be installed.  
Where skylights are located, ceiling insulation is to be installed to length of shaft.

No.	Date	Int.	Amendment changes as per cover sheet

- Notes
- Builder to verify all dimensions and levels on site prior to commencement of work
  - All work to be carried out in accordance with the current National Construction Code.
  - All materials to be installed according to manufacturers specifications.
  - Do not scale from these drawings.
  - No changes permitted without consultation with designer.

Designer:  
ANOTHER PERSPECTIVE PTY LTD  
PO BOX 21  
NEW TOWN  
LIC. NO. 685230609 (S. Turvey)  
Ph: (03) 6231 4122  
Fx: (03) 6231 4166  
Email:  
info@anotherperspective.com.au

Client / Project info  
PROPOSED RESIDENCE  
Lot 30, Spoonbill Loop,  
SORELL



**CALCULATIONS & SCHEDULES**

Drawn	ST	WH713965
Date	18 March 2024	Sheet
Scale		

10/03

**GUTTER OVERFLOW REQUIREMENTS** as per N.C.C. Figure 7.4.6a:  
 Minimum slot opening area of 1200 mm<sup>2</sup> per metre of gutter and the lower edge of the slots installed a minimum of 25 mm below the top of the fascia.  
 The acceptable overflow capacity must be 0.5 L/s/m.

**Batten fixings:**  
 100mm type 17, 14g bugle screws to comply with AS1684, or refer to AS1684 for alternatives.

**Batten spacing:**  
 75 x 38 F8 @ 900 Centre

**Colorbond fixings:**  
 50mm M6 11 x 50 EPDM seal to comply with AS3566 or refer to AS3566 for alternatives.

Roof Sheet Area (Approx)	Fascia Length (Approx)
215.82 m <sup>2</sup>	65.6 m

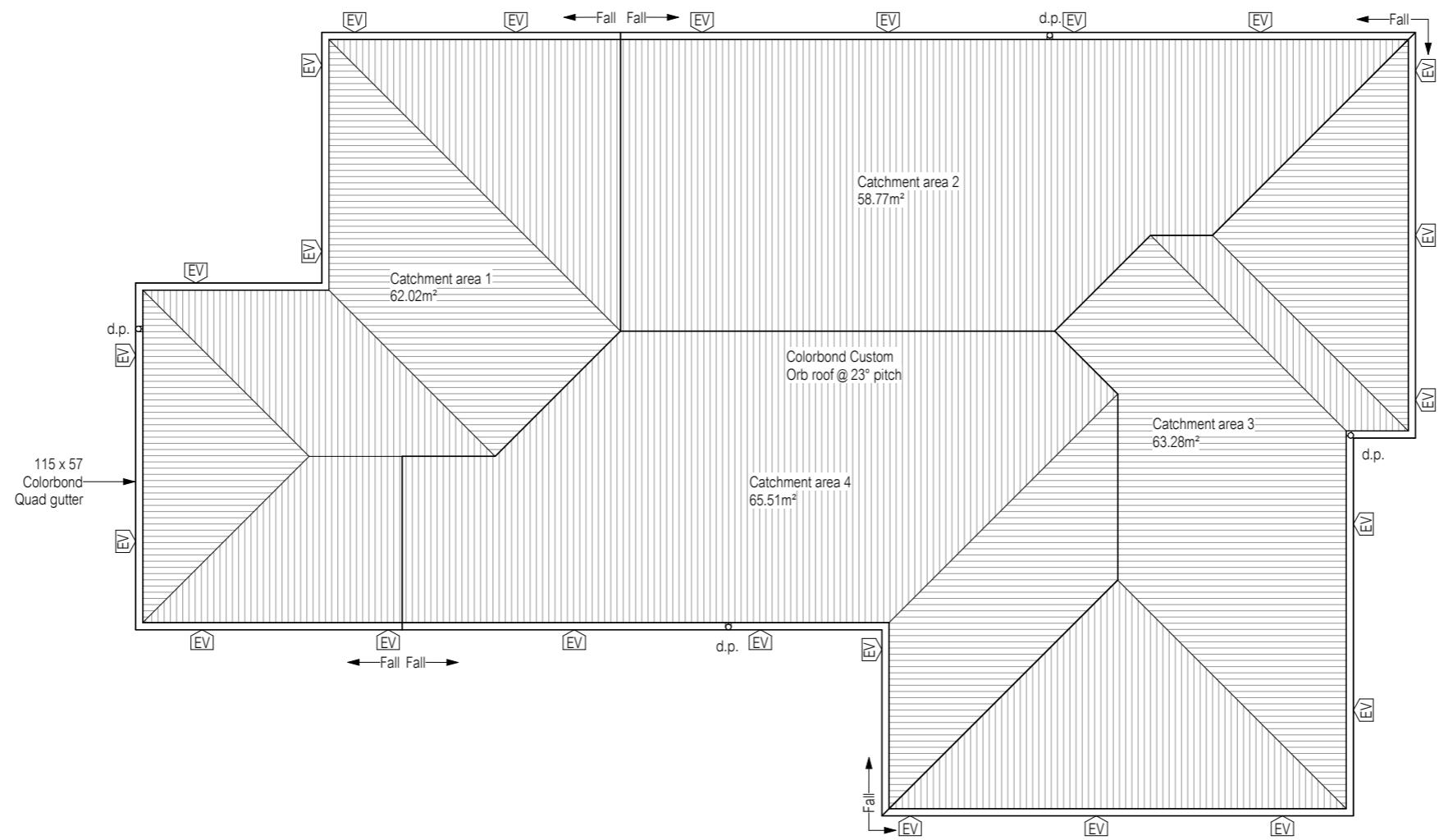

Position and quantity of downpipes are not to be altered without consultation with designer

Area's shown are surface areas / catchment areas, not plan areas.

Ah <sup>1</sup>	198.66	Area of Roof (excluding 115mm Quad gutter) (m <sup>2</sup> )
Ah <sup>2</sup>	206.26	Area of Roof (including 115mm Quad gutter) (m <sup>2</sup> )
Ac	249.57	Ah <sup>2</sup> x Slope factor (Table 3.2 from AS/NZS 3500.3) (m <sup>2</sup> )
Ae	6555	Cross sectional area of assumed 57 x 115 Quad Gutter. (mm <sup>2</sup> )
DRI	86.90	Design Rainfall Intensity (determined from Appendix D from AS/NZS 3500.3)
ACDP	74	Catchment area per Downpipe (determined from Figure 3.5.4(A) from AS/NZS 3500.3) (m <sup>2</sup> )
Required Downpipes	3.37	Ac ÷ Acdp
Downpipes Provided	4	

**EAVES VENT NOTE:**  
 BRADFORD POLY EAVE VENT TO BE INSTALLED EVERY 3m CONTINUOUS 5mm GAP TO RIDGE

<p><b>Sorell Council</b>          Development Application: Development Application - Lot 30 Spoonbill Loop, Sorell - P1.pdf          Plans Reference: P1          Date Received: 12/04/2024</p>	<p>Notes</p> <ul style="list-style-type: none"> <li>Builder to verify all dimensions and levels on site prior to commencement of work</li> <li>All work to be carried out in accordance with the current National Construction Code.</li> <li>All materials to be installed according to manufacturers specifications.</li> <li>Do not scale from these drawings.</li> <li>No changes permitted without consultation with designer.</li> </ul>	<p>Designer:</p> <p>ANOTHER PERSPECTIVE PTY LTD          PO BOX 21          NEW TOWN          LIC. NO. 685230609 (S. Turvey)          Ph: (03) 6231 4122          Fx: (03) 6231 4166          Email: info@anotherperspective.com.au</p>	<p>Client / Project info</p> <p>PROPOSED RESIDENCE          Lot 30, Spoonbill Loop,          SORELL</p>		<p><b>ROOF PLAN</b></p>						
		<table border="1"> <tr> <td>Drawn</td> <td>ST</td> <td>WH713965</td> </tr> <tr> <td>Date</td> <td>10 April 2024</td> <td>Sheet</td> </tr> <tr> <td>Scale</td> <td>1:100</td> <td></td> </tr> </table>	Drawn		ST	WH713965	Date	10 April 2024	Sheet	Scale	1:100
Drawn	ST	WH713965									
Date	10 April 2024	Sheet									
Scale	1:100										
<table border="1"> <tr> <td>No.</td> <td>Date</td> <td>Int.</td> <td>Amendment changes as per cover sheet</td> </tr> </table>	No.	Date	Int.	Amendment changes as per cover sheet							
No.	Date	Int.	Amendment changes as per cover sheet								